



PL2501SPH & PL2501SPV
Owner's Manual



Aerator Owner's Manual

PL2501SPH & PL2501SPV

Beginning Serial #: 0032618001

U.S. Patent #: 6892821

Original Instructions

IMPORTANT- READ CAREFULLY BEFORE USE AND KEEP FOR FUTURE REFERENCE

Table of Contents

| | |
|--|-------|
| Specifications, Intended Use, and Safety..... | 3 |
| Warning and Instruction Labels..... | 4-5 |
| Engine Labels, Engine Controls, and Packing Checklist..... | 6 |
| Operation..... | 7-8 |
| Maintenance..... | 8-23 |
| Troubleshooting..... | 24 |
| Spare Parts List and Warranty Information | 25 |
| Parts Drawings and Lists..... | 26-40 |

NOT FOR REPRODUCTION

Specifications

| | PL2501SPH | PL2501SPV |
|-------------------------|-----------------------|------------------------------|
| Engine | Honda GX160 w/Gearbox | Briggs and Stratton Vanguard |
| Engine Model No. | GX160UT2HX2 | 12V3 |
| Engine Fuel Capacity | 3.3 qt. (3.1 L) | 3.3 qt. (3.1 L) |
| Engine Oil Capacity | 0.63 qt. (0.58 L) | 0.63 qt. (0.58 L) |
| Total Unit Weight | 435lb (197.3kg) | 435lb (197.3kg) |
| Length | 67" (1.7 m) | 67" (1.7 m) |
| Width | 35" (0.89 m) | 35" (0.89 m) |
| Height | 38" (0.97 m) | 38" (0.97 m) |
| Maximum Operating Slope | 15° | 15° |

Intended Use

This machine is designed for aerating established lawns and large grass covered areas. The machine should not be used for any other purpose than that stated above.

⚠ DO NOT OPERATE IF EXCESSIVE VIBRATION OCCURS! If excessive vibration occurs, shut engine off immediately and check for damaged or worn tine crank, loose crank bearings or tines, loose engine or lodged debris. To remove debris from the machine, see the machine specific trouble shooting section.

Note: See parts list for proper bolt torque and specifications.

Safety

PROPOSITION 65 STATEMENT

⚠ WARNING 

This product can expose you to chemicals including gasoline engine exhaust, which is known to the State of California to cause cancer, and carbon monoxide, which is known to the State of California to cause birth defects or other reproductive harm. For more information go to www.P65Warnings.ca.gov.

Warning and Instruction Labels

The labels shown below were installed on your BILLY GOAT® Aerator. If any labels are damaged or missing, replace them before operating this equipment. Item numbers from the Illustrated Parts List and part numbers are provided for convenience in ordering replacement labels. The correct position for each label may be determined by referring to the Figure and Item numbers shown.

⚠ WARNING

Amputation and Pinch Point Hazard

To avoid injury from rotating parts, stay clear of parts and keep all shields and guards in place.



5103184

DECAL, WARNING, HAND IN BELT, ENG. ONLY P/N 5103184

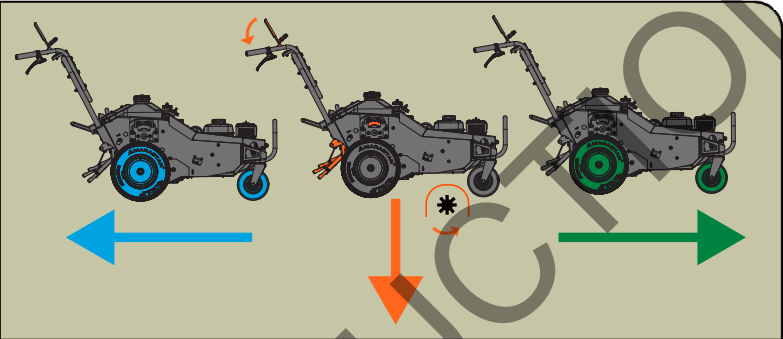
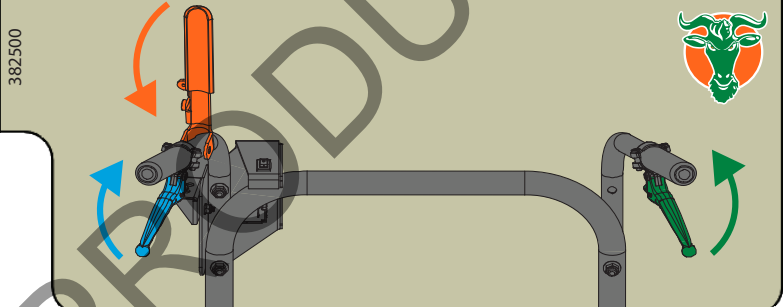

DECAL, OP INFO LEFT P/N 382500

Belt Serviceability

Read the Operator's Manual for complete belt servicing instructions.



382502

DECAL, BELT SERVICE P/N 382502

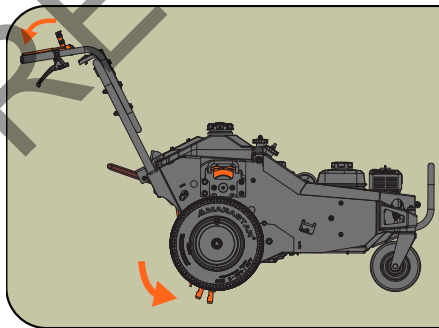

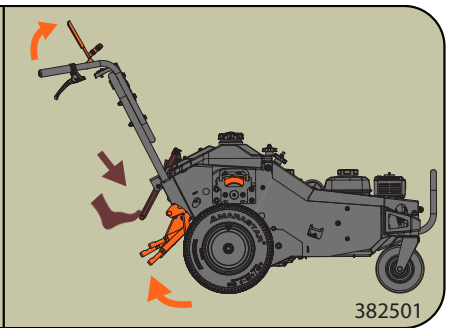

DECAL, OP INFO RIGHT P/N 382501

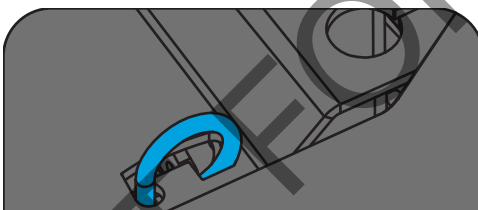

LEVER IN: FREE WHEEL



LEVER OUT: DRIVE ENABLED

382503

DECAL, BI PASS FUNCTION P/N 382503

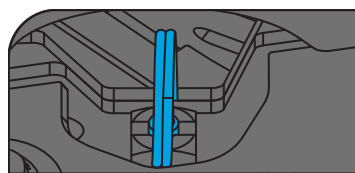



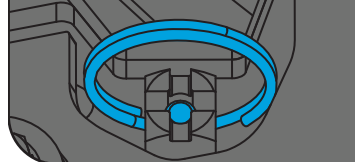



382504

DECAL, CASTER LOCK FUNCTION P/N 382504

Warning and Instruction Labels Continued

Adjusting Chain Tension

Adjust chain tension within first 10 hrs.



Read the Operator's Manual for complete chain servicing instructions.

382505

DECAL, ADJUST CHAIN TENSION
P/N 382505

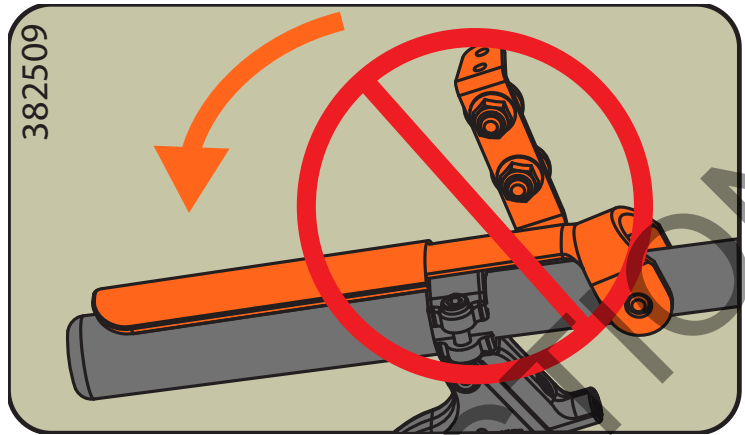

DECAL, NO CLUTCH P/N 382509

Text PLUG
to 33988 (U.S.)
& 33433 (CAN)
for helpful
Video Tutorial



382512

DECAL, T2V PLUG & SOIL
P/N 382508

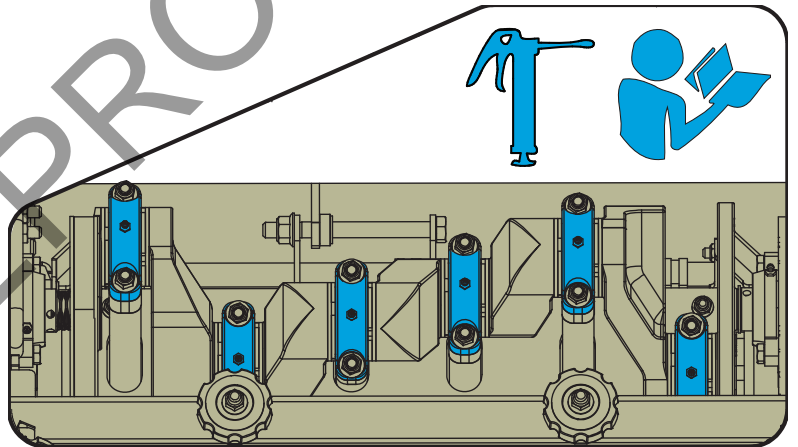

DECAL, MOLD IN WATER TANK LEFT

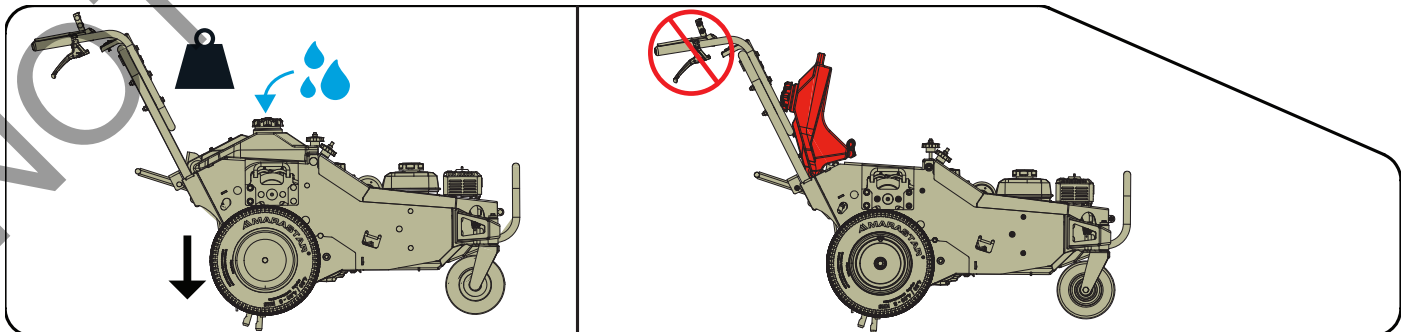

DECAL, MOLD IN WATER TANK RIGHT

Engine Labels - Honda

■ READ OWNER'S MANUAL BEFORE OPERATION.
 ■ LIRE LE MANUEL D'UTILISATEUR AVANT USAGE.
 ■ VOR INBETRIEBNAHME UNBEDINGT BETRIEBUNGSANLEITUNG DURCHLESEN.
 ■ NO UTILIZAR SINANTES NO HABER LEIDO EL MANUAL.
 HONDA MOTOR CO., LTD. MADE IN JAPAN

OIL ALERT

■ WHEN OIL LEVEL LOW, ENGINE STOPS IMMEDIATELY.

IMPORTANT ENGINE INFORMATION-HONDA MOTOR CO. LTD
 ENGINE FAMILY:THN163U1G1RA DISPLACEMENT - 163cm³
 TUNE UP SPECIFICATION *REFER TO OWNER'S MANUAL FOR
 MAINTENANCE SPECIFICATIONS AND ADJUSTMENTS * THIS ENGINE
 MEETS 1995 CALIFORNIA EMISSION REGULATIONS FOR
 UTILITY AND LAWN AND GARDEN EQUIPMENT ENGINES.

Engine Labels - Vanguard



POWER CODE
 IN-FIELD SUPPORT by VANGUARD™
 basco.com/patents • data rates apply

Serial #: XXXXXXXXXXXX
 Engine Model #: XXXXXXXXXXXX

EMISSION CONTROL INFORMATION
 BRIGGS & STRATTON CORPORATION

Refer to owner's manual for maintenance specs, adjustments, & emissions durability info. This engine meets U.S. EPA and California EXH/EVP SORE regulations for:

Model Year 2018 Displacement: 203cc 383164
 Exh Family: JBSXS.203HB
 Evp Family: CMH3 JBSXPNHEQM2
 EU: e11*97/68SA*2010/46*3570*00 (II) Air Index #: 3
 Most Clean 1 [] [] [] [] [] [] [] [] [] [] 10 Least Clean
 Emission Compliance Period: 500 hrs ECS: EM, CM
 DOM: May 2018

INTEGRATED CYCLONIC AIR CLEANER

6.5
 GROSS HP / 203cc
 4.8 GROSS KW
 AT 3,600 RPM PER SAE J1940

Engine Controls

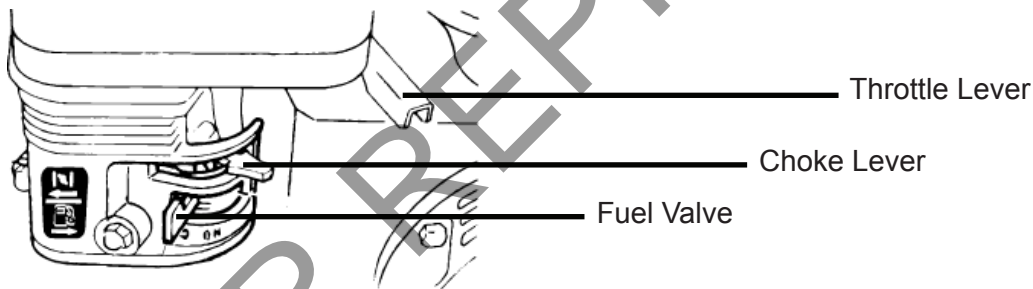

Packing Checklist

Your Billy Goat is shipped from the factory in one carton with the handles and cables detached.

Read all safety instructions before assembling unit.
Take caution when removing the unit from the box.

PUT OIL IN ENGINE BEFORE STARTING

PARTS BAG & LITERATURE ASSY

- Warranty card P/N- 400972
- Owner's Manual P/N- 382506
- Declaration of Conformity P/N-381503
- General Safety and Warnings Renovation Manual P/N-100295

Boxing Parts Checklist

- Owner's Manual (P/N 382506)
- Engine Manual (Honda) OR
- Engine Manual (Briggs and Stratton)



Operation

STARTING ENGINE

See engine manufacturer's instructions for type and amount of oil and gasoline used. Engine must be level when checking and filling oil and gasoline.

| | |
|----------------------|--|
| ENGINE SPEED | Controlled by lever on the engine. Under normal conditions, operate at the minimum throttle speed to accomplish your task. |
| ON/OFF SWITCH | Set the On/Off switch to the on setting. |
| FUEL VALVE | Move fuel valve to "ON" position. (Honda: Located below the air cleaner on the engine.) |
| CHOKE | Engage the choke when starting a cold engine. (Honda: Located below the air cleaner on the engine.) |
| THROTTLE | Move the throttle control lever on the engine to fast position. Pull starting rope to start engine |

If your unit fails to start, check trouble shooting section in operator's manual and also see engine manual.

NOTE: Honda engines are equipped with a low oil sensor to prevent engine damage. When it senses a low oil condition (i.e. unit is operating or sitting on a steep slope) the engine shuts down. The low oil condition must be corrected before the engine can be restarted. See the engine owner's manual for more information.

AERATING OPERATION

NOTE: NEVER PARK THIS UNIT ON A SLOPE OF ANY KIND. Always keep tines in the up position when parking the unit.

| | |
|-----------------------|---|
| ENGAGING DRIVE | Squeeze the right-hand speed control lever for forward motion and the left-hand speed control lever for reverse. The harder you squeeze, the faster the machine will go. Remember to only engage in reverse with the tines up. |
| TURNING | This machine has in-ground turning. At the end of an aerating run, turn the machine around while keeping the forward speed control and clutch lever engaged to make the next run. If a 3-point turn is desired, disengage the clutch lever and depress the foot pedal to return the tines to the transport (ensure tines are completely out of the ground before lifting), then squeeze the left-hand speed control lever to reverse the machine into position to make the next run. Re-engage the clutch and forward speed control to continue aerating. |
| TRANSPORTING | Be sure to raise tines out of the ground (disengage the clutch and depress the foot pedal) before transporting away from the work area. |

Operation

TIPS

- **MOW** - Mow the lawn to its normal cut height.
- **WATER** - For the best performance and maximum tine penetration the lawn should be thoroughly watered the day before aeration.
- **INSPECT** - Check the lawn before beginning work. Remove all rocks, wire, string, or other objects that can present a hazard during work prior to starting.
- **IDENTIFY** - Mark all fixed objects to be avoided during work, such as sprinkler heads, water valves, buried cables, or clothes line anchors, etc.
- **SLOPES** - Do not operate the aerator on steep slopes (exceeding 15°). Use extreme caution when operating on any sloped surface. For lesser sloped areas operate the unit, traversing up and down at a 45° angle to the slope rather than straight across. Extended operation on steep slopes can cause engine damage.

NOTE: Honda engines are equipped with a low oil sensor to prevent engine damage. When it senses a low oil condition (i.e. unit is operating or sitting on a steep slope) the engine shuts down. The low oil condition must be corrected before the engine can be restarted. See the engine owner's manual for more information. For increased wheel traction, fill the on-board tank with water (approximately five gallons).

Maintenance

PERIODIC MAINTENANCE

Periodic maintenance should be performed at the following intervals:

| Maintenance Operation | Every Use (daily) | Every 10 Hrs | Every 50 Hrs | Every 100 Hrs |
|--|-------------------|--------------|--------------|---------------|
| Inspect for loose, worn or damaged parts | • | | | |
| Check engine oil* | • | | | |
| Inspect belt for wear | | | • | |
| Engine (See engine manual) | • | | | |
| Grease Cam bearings (recommend using Almagard #3752) | | • | | |
| Thoroughly clean all debris from unit and tines | • | | | |
| Replace tine bushings | | | | • |
| Grease shaft bearings and caster wheel bearings | | | | • |

*ENGINE MUST BE LEVEL WHEN CHECKING OR FILLING OIL

INDIVIDUAL TINE REPLACEMENT

1. Wait for engine to cool and disconnect spark plug.
2. Loosen the jam nut then unscrew the tine.
3. Replace the tine making sure to use the maximum amount of threads on the tine.
4. Use a torque wrench to tighten to 100 ft-lbs.

NOTE: Tines are a normal wear item and should be inspected regularly for signs of wear or damage.

ADJUSTING DRIVE BELT TENSION

1. The drive belt tension can be adjusted with the eyebolt that is connected to the spring. Loosen the eyebolt with two 9/16" wrenches. Spin the forwardmost nut towards the eyebolt. Tighten the rearmost nut to stretch the spring which will increase the belt tension. Tighten the forwardmost nut down once proper tension is achieved.

DRIVE BELT REPLACEMENT

1. Disconnect the spark plug.
2. Slide the tine drive belt off of the engine pulley and tuck it back toward the rear of the machine
3. Using a 3/8" ratchet and 6" extension or 3/8" break-over bar, insert the end of the extension into the square hole on the idler arm. Push counterclockwise to stretch the spring and free the belt from the idler pulley.
4. Disconnect the spring from the eyebolt and slide the idler arm toward the engine.
5. Walk the worn out/damaged belt off of the engine and transmission pulley and remove from machine. (Note how the belt is routed before complete removal for ease in Step 6).
6. Re-install the new belt (Note: twist drive, make sure the "V" side of the belt is seated into each pulley to ensure proper operation).
7. Reconnect spring to eyebolt
8. Use square hole to stretch spring and set the belt back into the pivoted idler.
9. Re-install tine drive belt on engine pulley.

SWING ARM BUSHING REPLACEMENT

1. Disconnect the lift link from swing arm support bar. Use an impact/socket wrench fitted with a 3/4" socket to remove the 1/2" bolt (see Figure A, circled in yellow). Set hardware aside to be reattached later.
2. Detach the swing arm support bar. Use an impact/socket wrench fitted with a 1/2" socket to remove the four 5/16" bolts and associated hardware (see Figure A, circled in orange). Set hardware aside to be reattached later. Remove the swing arm support bar. At this stage, your machine should appear as in Figure B.

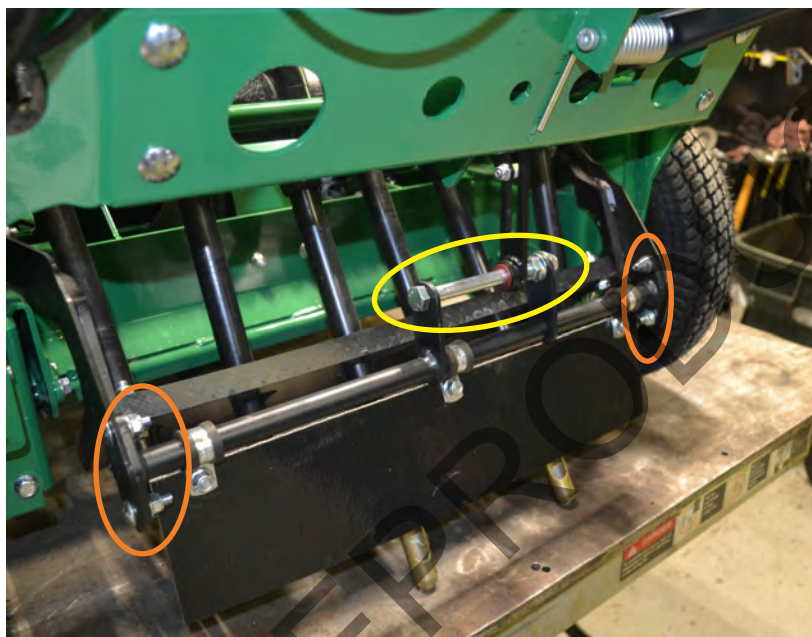

Figure A



Figure B

SWING ARM BUSHING REPLACEMENT CONTINUED

3. Detach the tine plate. Use an impact/socket wrench fitted with the 1/2" socket to remove the four bolts and associated hardware that secure the tine plate (see Figure C). Set hardware aside to be reattached later. Using your hands, gently maneuver the plate down off of the tines (see Figure D). Set the plate aside to reattach later.



Figure C



Figure D

4. Remove the swing arm (see Figure E, circled in blue). Use an impact/socket wrench fitted with a 9/16" socket OR a 9/16" wrench to remove the bolt securing the swing arm. Repeat this step to detach the second swing arm.



Figure E

5. Remove the old and/or broken bushing from swing arm. Securely clamp down the swing arm. Use a punch and hammer to tap out the old and/or broken bushing from the swing arm. See Figure F.

SWING ARM BUSHING REPLACEMENT CONTINUED



Figure F

6. Place new bushings in swing arms. Use 1/2" pin or shoulder bolt to position the new bushing into the swing arm. Use a hammer to gently tap on the pin/shoulder bolt to drive the new bushing into the swing arm. Remove the 1/2" pin or shoulder bolt.
7. Repeat steps 5 & 6 on the second swing arm.
8. Reverse steps 1-4. Reattach the swing arms, then reattach the tine plate. Proceed to reattach the swing arm support bar. Finally, reconnect the link lift to the swing arm support bar.
9. Tighten all joints. Use an impact wrench with correct sockets to ensure the all joints are secure before operation. Ensure hardware orientation is the same as before disassembly.

TINE PLATE REPLACEMENT

1. Disconnect the link lift from swing arm support bar. Use an impact wrench fitted with a 3/4" socket to remove the 1/2" bolt (see Figure A, circled in yellow). Set hardware aside to be reattached later.
2. Detach the swing arm support bar. Use an impact wrench fitted with a 1/2" socket to remove the four 5/16" bolts and associated hardware (see Figure A, circled in orange). Set hardware aside to be reattached later. Remove the swing arm support bar. At this stage, your machine should appear as in Figure B.
3. Detach the tine plate. Use an impact wrench fitted with the 1/2" socket to remove the four bolts and associated hardware that secure the tine plate (see Figure C). Set hardware aside to be reattached later. Using your hands, maneuver the plate down off of the tines (see Figure D).
4. Attach new tine plate. Maneuver the new plate over the tines. Secure into place with original hardware from Step 3.
5. Reverse Steps 1 & 2. Reattach swing arm support bar then reconnect the link lift to the swing arm support bar.
6. Tighten all joints. Use the impact wrench with correct sockets to ensure the all joints are secure before operation. Ensure hardware orientation is the same as before disassembly.

ADJUSTING CHAIN TENSION

Note: Text “PLUG” to 33988 for a helpful video tutorial about adjusting the chain tension on your aerator.

Note: If possible, lift up the rear of the machine for easier access to undercarriage during this procedure.

1. Remove the bolts holding shield into place. Use an impact/socket wrench fitted with a 1/2” socket to remove the three bolts which secure the shield. For ease, remove each bolt in the following “ABC” order. **Note:** Pictures are of operator’s righthand side shield.

A. The first bolt is circled in orange. See Figure G.

B. The placement of the second bolt is circled in blue. See Figure H. (Note that in Figure H the bolt has already been removed).

C. The third bolt is circled in yellow. See Figure G.



Figure G



Figure H

ADJUSTING CHAIN TENSION CONTINUED

2. Remove shield covering the chain. Use your hands to gently slide the shield out of place (downwards and towards the center of the machine). See Figure I. Set aside the shield to reattach once the chain is adjusted. You now have access to the chain to adjust its tension.



Figure I

3. Adjust chain tension. Use two 3/4" wrenches on the bolt in the idler sprocket slot. Loosen bolt to adjust tension. For tighter chain tension, push the bolt up and tighten. For looser tension, pull the bolt down and tighten. See Figures J and K.



Figure J

ADJUSTING CHAIN TENSION CONTINUED

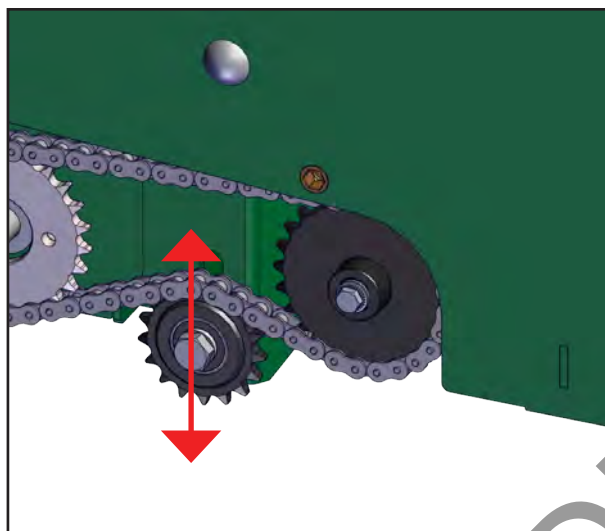

Figure K

4. Reverse steps 1 & 2 to reassemble your machine.

5. Tighten all joints. Use an impact/socket wrench with the 1/2" socket to ensure the all joints are secure before operation.

Note: There are chain drives on both the right and lefthand sides of this machine. Be sure to adjust BOTH chains for proper functionality and operation.

REPLACING THE BELT

Note: Text "PLUG" to 33988 for a helpful video tutorial about replacing the belt on your aerator.

1. Open up the machine. Use your hands to loosen the knobs holding down the water tank and hood. See Figure L. Lift up the water tank, and then lift up the hood to access the belt system. See Figure M.



Figure L



Figure M

REPLACING THE BELT CONTINUED

2. Loosen tine crank mounting plate from frame.

2.1 Use an impact/socket wrench fitted with a 9/16" socket to remove the 3/8" bolts and associated hardware connecting the plate to the frame. See Figure N (the bolts to be removed are circled in yellow). Set one of the bolts and its associated washer aside to reattach later.



Figure N

2.2 Take the remaining bolt and washer and start the threads into the tine shaft through the center hole on the mounting plate. DO NOT TIGHTEN. See Figure O (the hole is circled in orange).

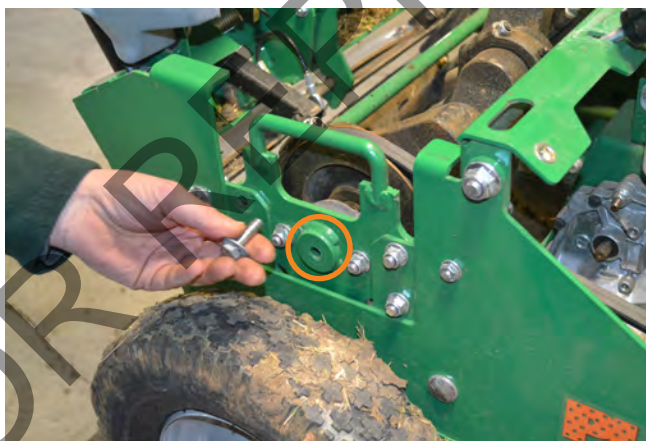

Figure O

2.3 Proceed to remove the carriage bolts from the right side of the plate. See Figure P.



Figure P

REPLACING THE BELT CONTINUED

2.4 Finally, tighten the bolt in the center hole to shift the mounting plate forward. See Figure Q. At this stage, your machine should appear as shown in Figure R.



Figure Q



Figure R

3. Remove worn/broken belt. Take the belt loose from the engine pulley and idler pulley. Then pull up on the handle of the tine crank mounting plate as shown in Figure S. You may need to rotate the crank mounting plate forward and backward to completely clear the belt. Gently pull the old belt off the tine crank pulley and feed out of machine. See Figure T.



Figure S



Figure T

REPLACING THE BELT CONTINUED

4. Install new belt. Pull up on the handle of the tine crank mounting plate and feed the belt into the machine as shown in Figure U. Ensure the belt is positioned correctly. See Figures V, W, and X. Engage the clutch to ensure belt functions properly.



Figure U



Figure V

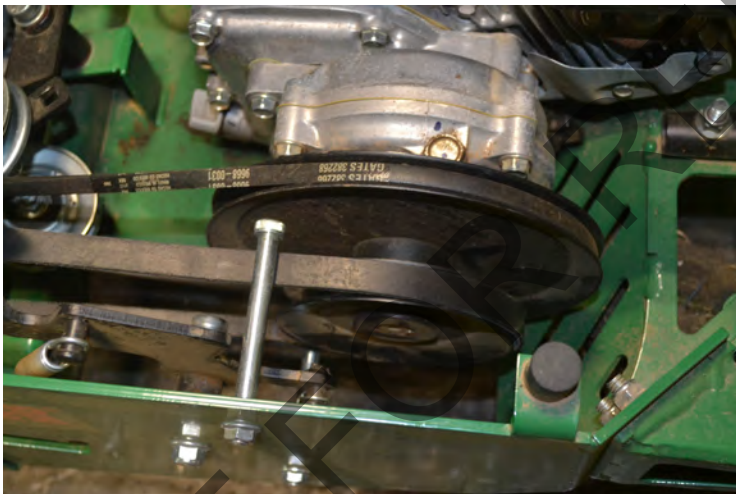

Figure W



Figure X

5. Reverse steps 1 & 2 to reassemble machine. Be sure to tighten all joints for safe operation.

BURPING THE TRANSMISSION

1. Lift the rear of the machine off the ground using a floor jack, jack stands, or similar tool of your choice.
2. Remove the cap on the expansion tank to add oil (10W-30 or 20W-50). Add oil to the “FULL COLD” line at the bottom of the tank. See Figure Y. Keep the cap off the tank.



Figure Y

3. Push the bypass lever into “FREE WHEEL” position (see Figure Z) and start the engine.

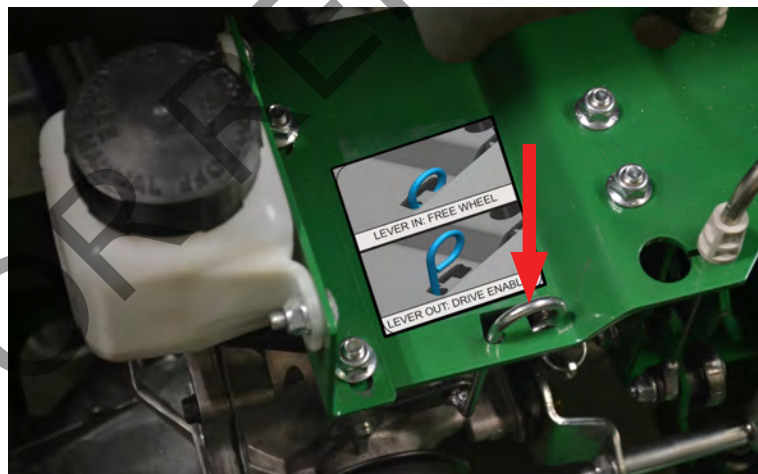

Figure Z

BURPING THE TRANSMISSION CONTINUED

4. From the operator's position, engage the forward lever, hold for about five seconds, and then disengage (See Figures AA and AB). Proceed to engage the reverse lever, hold for five seconds, and then disengage (See Figures AC and AD). Next, cycle this procedure 4-5 times.



Figure AA



Figure AB

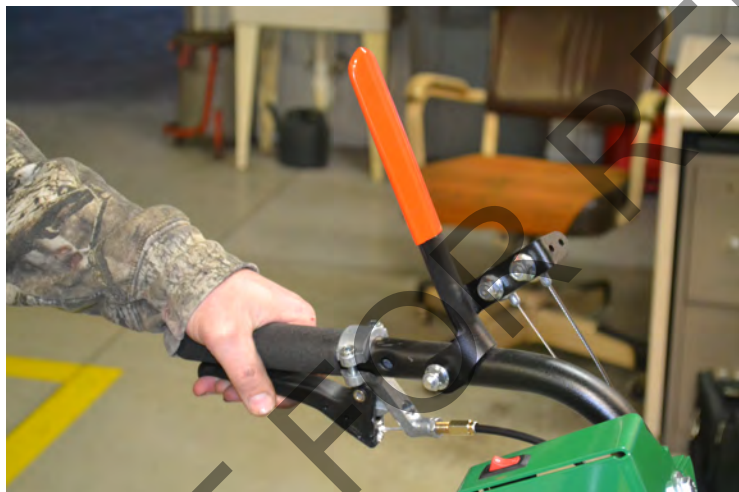

Figure AC



Figure AD

BURPING THE TRANSMISSION CONTINUED

5. Next, move the bypass lever to “DRIVE ENABLED” position (See Figure AE). Add more oil to transmission tank if necessary. Return to the operator’s position and repeat Step 4.

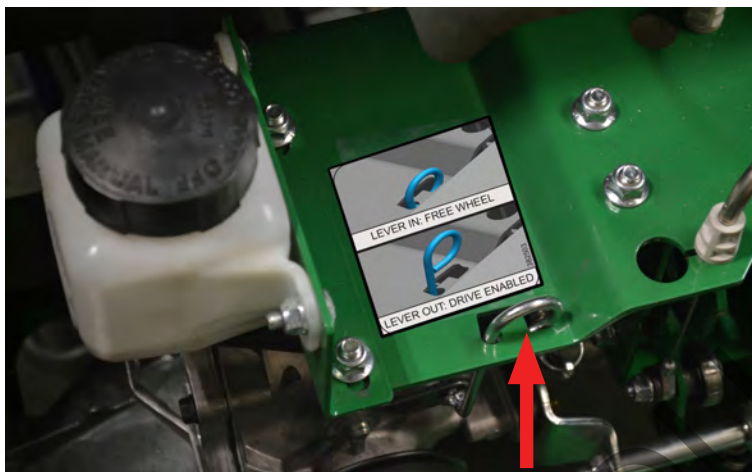

Figure AE

6. Repeat steps 2-5 until:
- Oil no longer releases bubbles.
 - Wheels successfully move in reverse at full speed when reverse lever is engaged.
 - Wheels successfully move forward at full speed when forward lever is engaged.

Note: This procedure will be easier to complete with two people. One person should remain in the operator’s position, engaging levers. Simultaneously, the second person should watch for the air bubbles to cease.

ADJUSTING THE CLUTCH CABLE

1. Locate the clutch cable on your machine as shown in Figure AF. The clutch cable is circled in red.

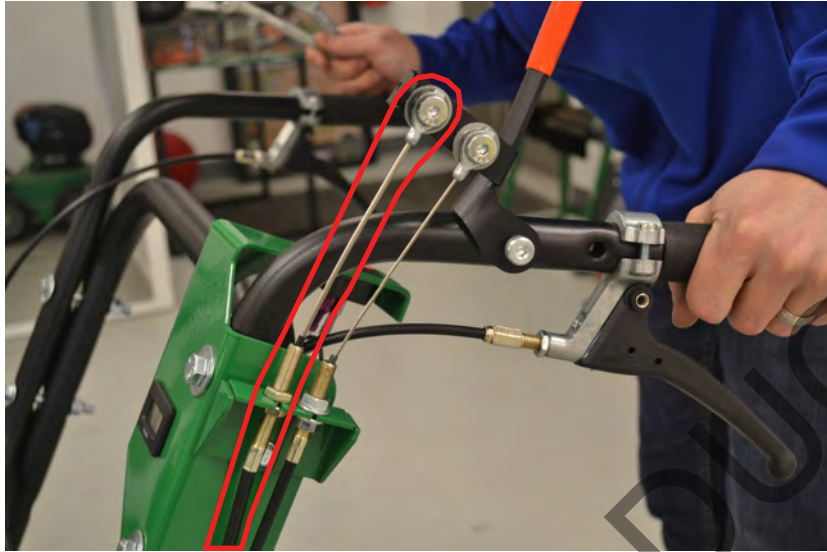

Figure AF

2. Simultaneously use two 1/2" wrenches to loosen the two lock nuts which secure the clutch cable. See Figure AG.

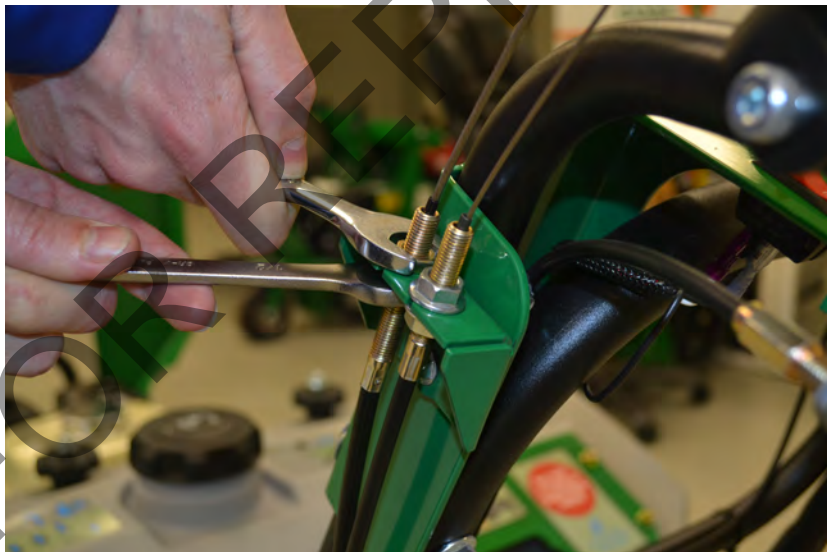

Figure AG

3. The cable should now be loose enough to move in the vertical direction. Gently pull down on the cable to increase the belt tension.
4. Reverse Step 2 to tighten the lock nuts and secure the cable back in place.

ADJUSTING THE AUTO-ENGAGE CABLE

1. If the tines on your aerator do not drop with ease when the clutch lever is engaged, you may need to adjust the auto-engage cable. Locate the cable on your machine as shown in Figure AH. The auto-engage cable is circled in red.



Figure AH

2. Simultaneously use two 1/2" wrenches to loosen the two lock nuts which secure the auto-engage cable. See Figure AI.

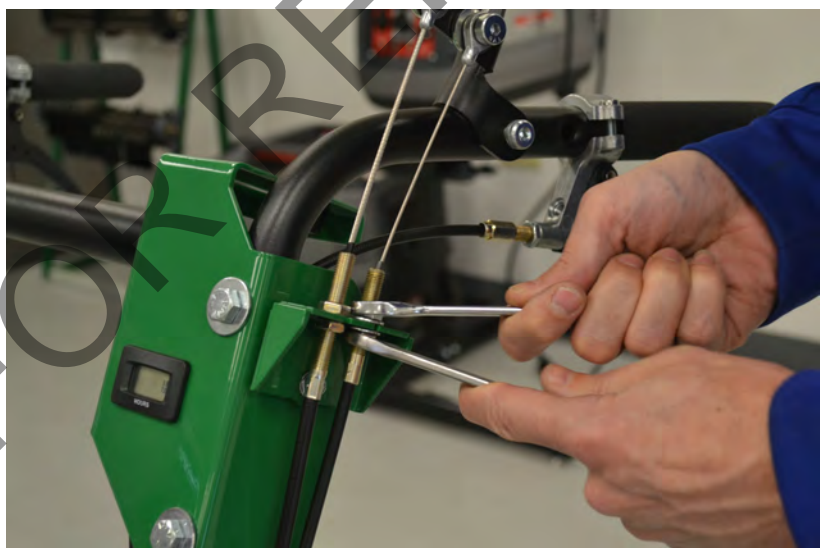

Figure AI

3. The cable should now be loose enough to move in the vertical direction. Gently pull down on the cable to allow tines to drop with ease.

4. Reverse Step 2 to tighten the lock nuts and secure the cable back in place.

Troubleshooting

| Problem | Possible Cause(s) | Solution(s) |
|--|--|---|
| Engine will not start. | <ul style="list-style-type: none"> • Stop switch off. • Throttle in off position. • Engine not in full choke position. • Out of gasoline. • Bad or old gasoline • Spark plug wire disconnected. • Dirty air cleaner. • Engine oil level too low (Honda only) | <ul style="list-style-type: none"> • Check stop switches, throttle, choke position, and gasoline. • Connect spark plug wire. • Clean or replace air cleaner or contact a qualified service person. • Check and fill engine oil. |
| Abnormal Vibration | <ul style="list-style-type: none"> • Damaged or missing tines. • Loose handle bolts. • Loose engine bolts. • Loose engine pulley | <ul style="list-style-type: none"> • Stop work immediately! • Replace any damaged or missing tines. • Tighten all loose bolts and nuts. |
| Engine stalls or labors when aerating | <ul style="list-style-type: none"> • Working on too steep of a slope. • Not enough oil in the engine. | <ul style="list-style-type: none"> • Work at 45 degrees to the slope. Move up and down instead of across the slope. • Check engine and add engine oil. |
| Engine is locked, will not pull over | <ul style="list-style-type: none"> • Tension on tine drive belt. • Engine problem. | <ul style="list-style-type: none"> • Pull spark plug wire and remove debris. • Inspect clutch cable for loose connection or damage. • Contact an engine servicing dealer for engine problems. |
| Unit does not move when clutch is engaged. | <ul style="list-style-type: none"> • Transmission in bypass position. • Belt drive out of adjustment. • Worn drive belt. • Loose or damaged pulleys. • Damaged, loose, or broken clutch cable. | <ul style="list-style-type: none"> • See maintenance on pages 9-21 of this manual. • Contact a qualified servicing dealer. |

Spare Parts List

Please refer to this list of spare parts you may need to service your BILLY GOAT® Aerator. You can order these parts through our customer service team. Please refer to our website at www.billygoat.com.

| Part Number | Description | Application |
|-------------|-------------------------------------|----------------------|
| 382244 | TINE, PLUGR .625"-11 BLACK | Aerator Tine |
| 382227 | GATE, 6 TINE | Plastic Tine Plate |
| 382273 | BELT, V, 5L 61.82EL OHR ETH, AMD CD | Tine Drive Belt |
| 380213 | BEARING JOURNAL 2" DIA | Tine Rod Cap Bearing |
| 373300 | WHEEL, 8" X 3" HEAVY DUTY | Caster Wheel |
| 382268 | BELT, V, 3V 53.00EL OHR CL, PLY CD | Drive Belt |
| 382239 | ASM, WHEEL & TIRE PLUGR TURF | Rear Wheel and Tire |

Warranty Information

When servicing engine refer to specific manufacturer's engine owner's manual. Engine warranty is covered by the specific engine manufacturer. If your engine requires warranty or other repair work contact your local servicing engine dealer. When contacting a dealer for service it is a good idea to have your engine model number available for reference (See table page 3). If you cannot locate a servicing dealer in your area you can contact the manufacturer's national service organization.

American Honda: 800-426-7701

Briggs and Stratton: 414-479-8008

Warranty Claim Procedure

Should a BILLY GOAT® machine fail due to a defect in material and/or workmanship, the owner should make a warranty claim as follows:

- The machine must be taken to the dealer from whom it was purchased or to an authorized Servicing BILLY GOAT Dealer.
- The owner must present the remaining half of the Warranty Registration Card, or, if this is not available, the invoice or receipt.
- The Warranty Claim will be completed by the authorized BILLY GOAT Dealer and submitted to their respective BILLY GOAT Distributor for their territory Attention: Service Manager. Any parts replaced under warranty must be tagged and retained for 90 days. The model number and serial number of the unit must be stated in the Warranty Claim.
- The distributor service manager will sign off on the claim and submit it to BILLY GOAT for consideration.
- The Technical Service Department at BILLY GOAT will study the claim and may request parts to be returned for examination. BILLY GOAT will notify their conclusions to the distributor service manager from whom the claim was received.
- The decision by the Technical Service Department at BILLY GOAT to approve or reject a Warranty Claim is final and binding.

For online product registration go to www.billygoat.com

PL2501SP Parts Drawings & Lists

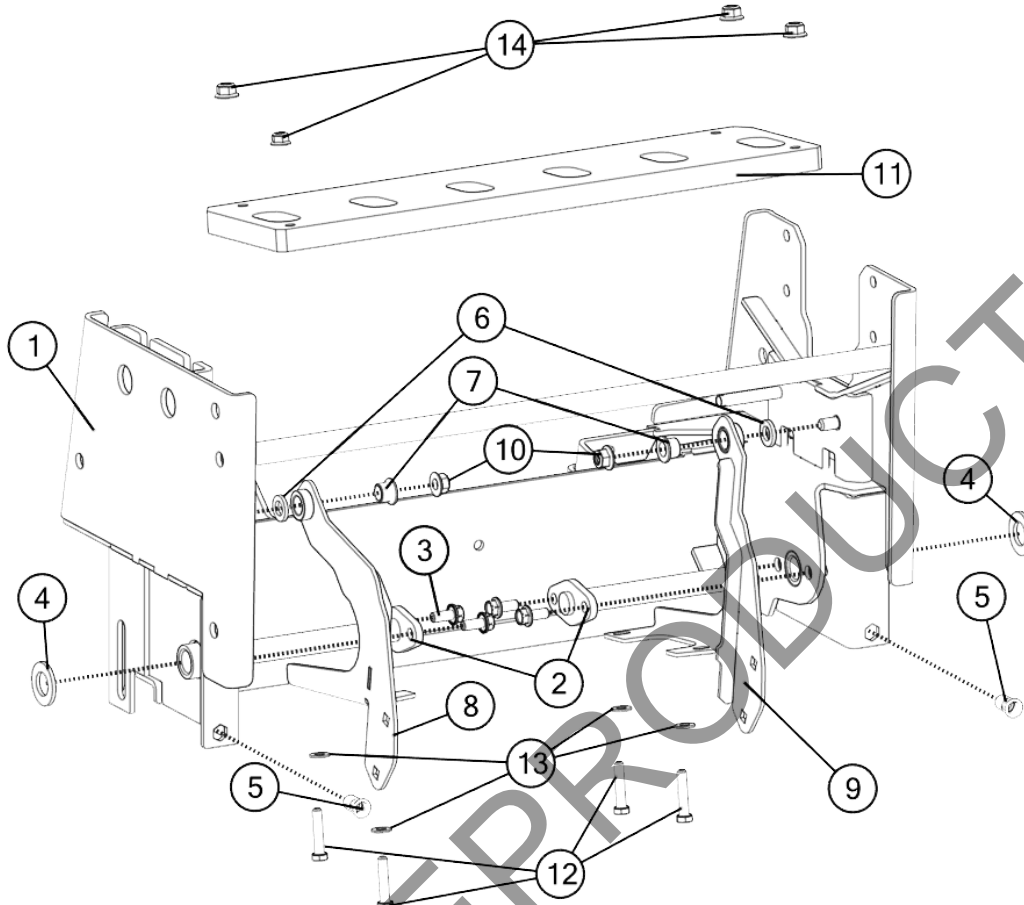

PL2501SPH & PL2501SPV

| Item No. | Description | Part No. | QTY |
|----------|---|----------|-----|
| 1 | WLDMT, SUB FRAME 2501SP | 382102-S | 1 |
| 2 | WA, AXLE REAR | 382103 | 2 |
| 3 | SER, HEX WSHR FLNG SCREW 5/16" - 18 x 0.75" | 351264 | 4 |
| 4 | WSHR-STL, FLT, .812"X1.469"X.134" SAE ZP | 8172015 | 2 |
| 5 | NUT INSERT HEX 5/16"-18, .150-.312 GRIP RANGE | REF | 2 |
| 6 | WSHR-NYL, FLT, .500" X .875" X .125" | 382258 | 2 |
| 7 | BUSHING, .500" I.D. | 362254 | 2 |
| 8 | WA, TINE GATE ARM LH | 382101 | 1 |
| 9 | WA, TINE GATE ARM RH | 382104 | 1 |
| 10 | NUT-HEX-NYLK, FLG .375-16 ZP | 8165003 | 2 |
| 11 | GATE, TINE | 382227 | 1 |
| 12 | SCR-CAP, HEX .3125"-18 X 1.500" G5 ZP | 8041030 | 4 |
| 13 | WSHR-STL, FLT, .344"X.688"X.065" SAE ZP | 8172008 | 4 |
| 14 | NUT-HEX-NYLK, FLG .3125-18 ZP | 8165002 | 4 |

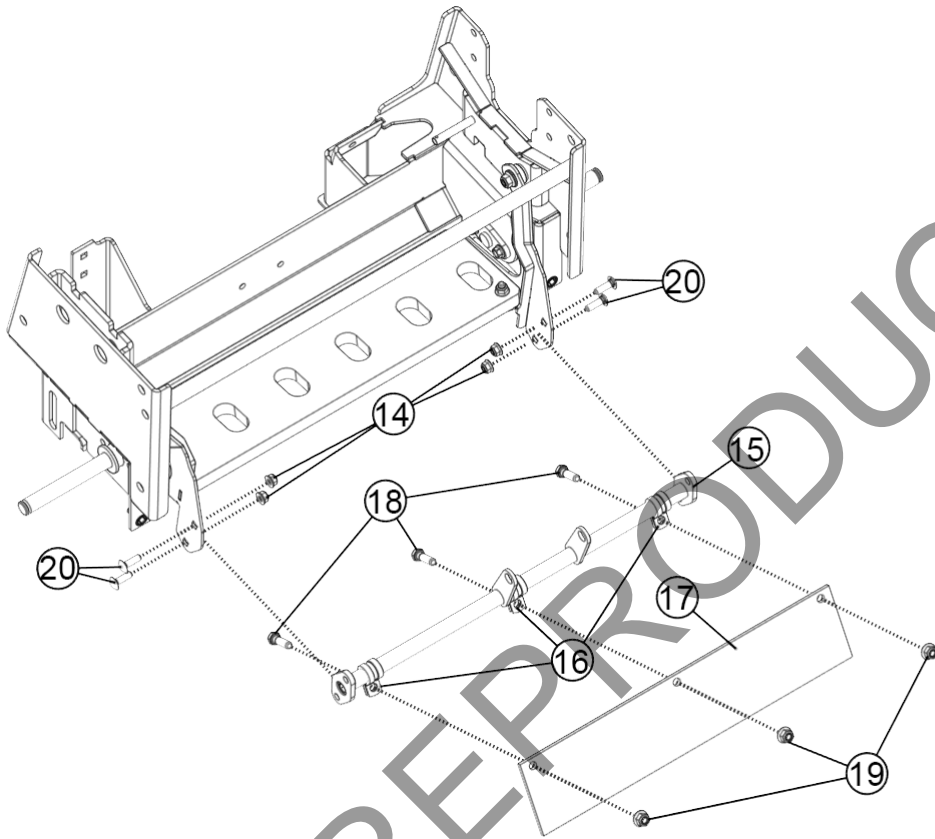

PL2501SPH & PL2501SPV

| Item No. | Description | Part No. | QTY |
|----------|---|----------|-----|
| 14 | NUT-HEX-NYLK, FLG .3125-18 ZP | 8165002 | 4 |
| 15 | WA, TINE GUARD | 382118 | 1 |
| 16 | CLAMP, P LOOM Ø.750, .406" MH | 382203 | 3 |
| 17 | SKIRT, TINE RUBBER | 382280 | 1 |
| 18 | SCREWCAP 3/8"-16 X 1 1/4" HCS ZP | 8041051 | 3 |
| 19 | NUT-HEX-NYLK, FLG .375"-16 ZP | 8165003 | 3 |
| 20 | BOLT, CARRIAGE 5/16-18 X 1" ZP SHORT NK | 362362 | 4 |

PL2501SP Parts Drawings

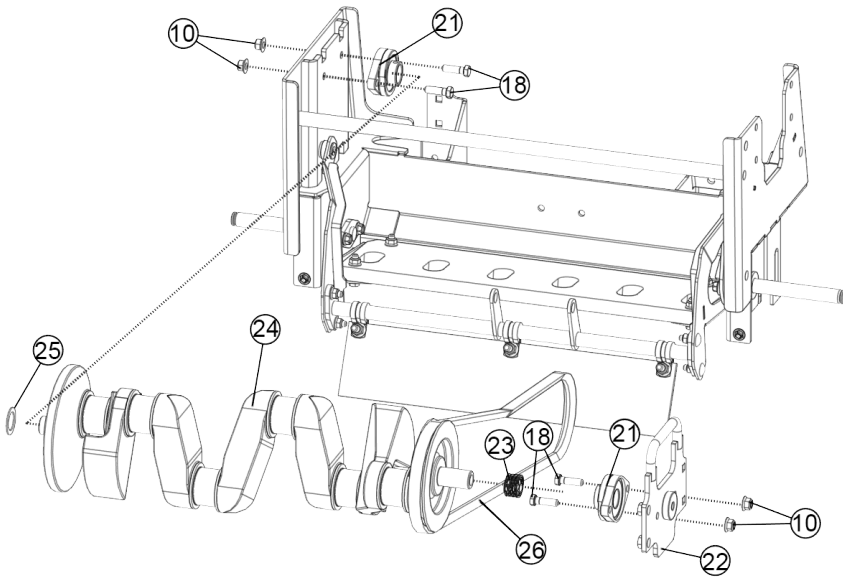

PL2501SPH
&
PL2501SPV

| Item No. | Description | Part No. | QTY |
|----------|---|----------|-----|
| 10 | NUT-HEX-NYLK, FLG .375-16 ZP | 8165003 | 4 |
| 18 | SCREWCAP 3/8"-16 X 1 1/4" HCS ZP | 8041051 | 4 |
| 21 | BRG, 2-SQ.HOLE MNT, 1.00 BORE DCT. IRON | 382236 | 2 |
| 22 | WA, CRANK BEARING MNT | 382112 | 1 |
| 23 | SPRING, WAVE 1.000" X .700" | 382220 | 1 |
| 24 | CRANK, 6 TINE | 382242 | 1 |
| 25 | MACHINERY BUSHING 1" X 1 1/2 X 14 GA | 362205 | 1 |
| 26 | BELT, V, 5L 61.82EL OHR ETH, AMD CD | 382273 | 1 |

PL2501SPH
&
PL2501SPV

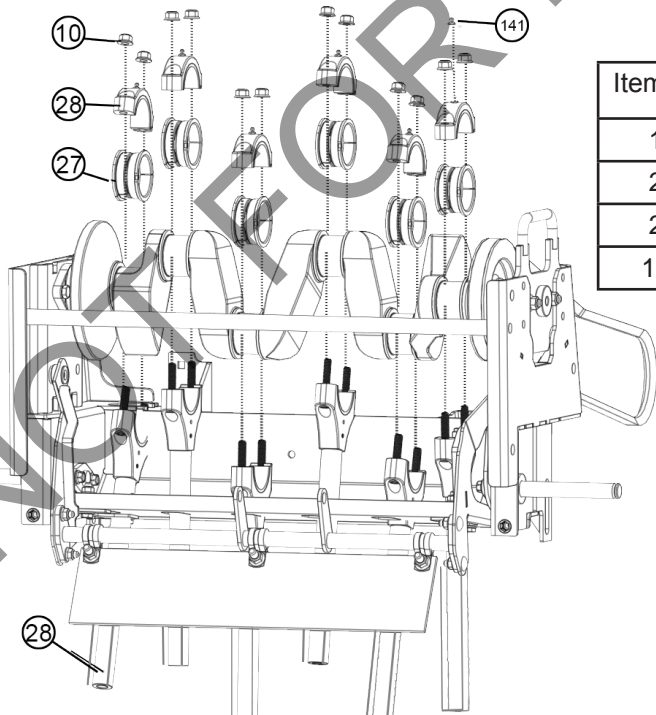

| Item No. | Description | Part No. | QTY |
|----------|---------------------------------------|----------|-----|
| 10 | NUT-HEX-NYLK, FLG .375-16 ZP | 8165003 | 4 |
| 27 | BEARING JOURNAL 2" DIA | 380213 | 12 |
| 28 | ASM, TINE ROD AND CAP | 382264 | 6 |
| 141 | ZERK, GREASE STR .250"-28 X .359" TPR | 382341 | 6 |

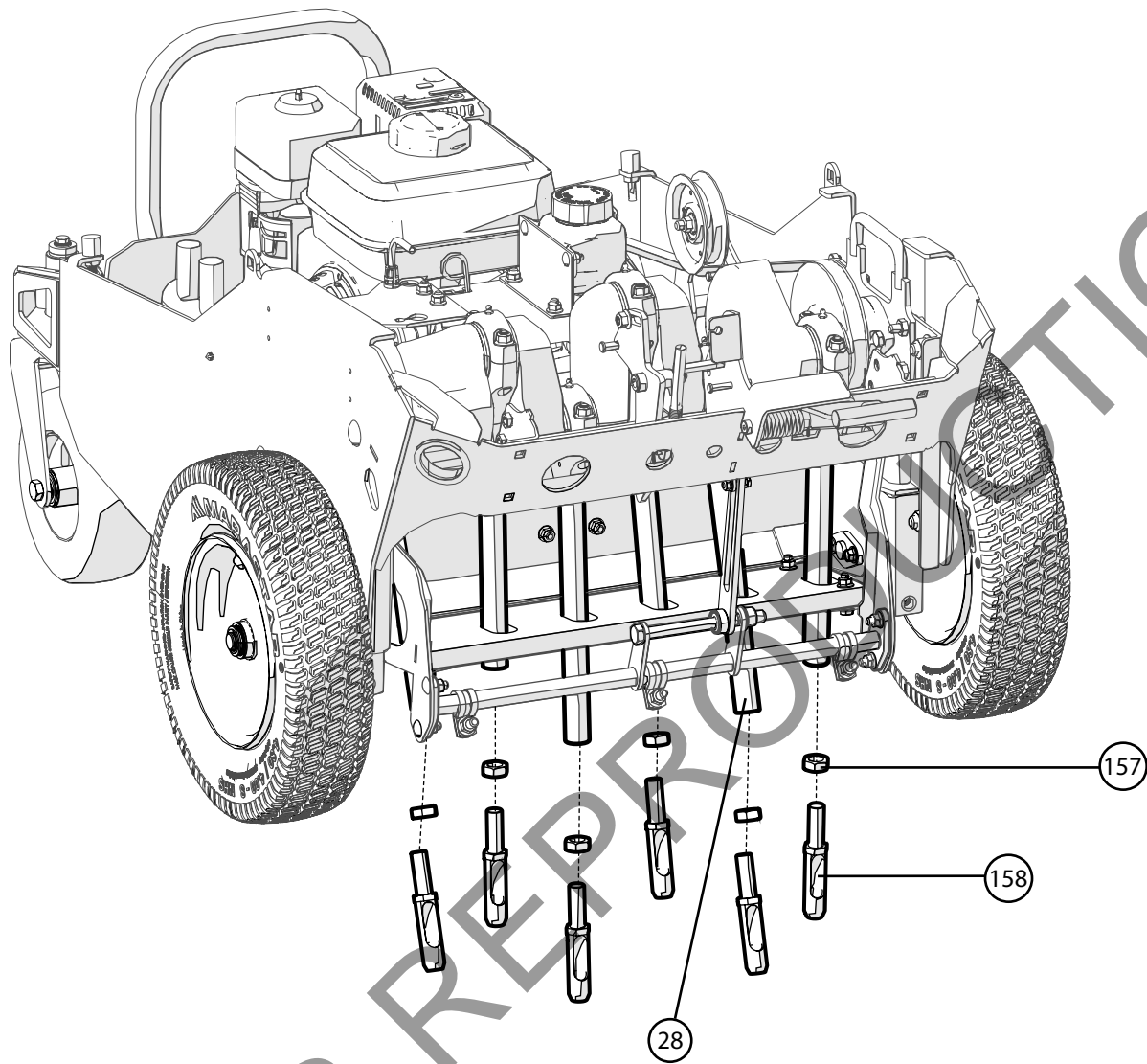

PL2501SPH & PL2501SPV

| Item No. | Description | Part No. | QTY |
|----------|----------------------------|----------|-----|
| 28 | ASM, TINE ROD AND CAP | 382264 | 6 |
| 157 | NUT JAM, 5/8-11 ZP | 8143007 | 6 |
| 158 | TINE, PLUGR .625"-11 BLACK | 382244 | 6 |

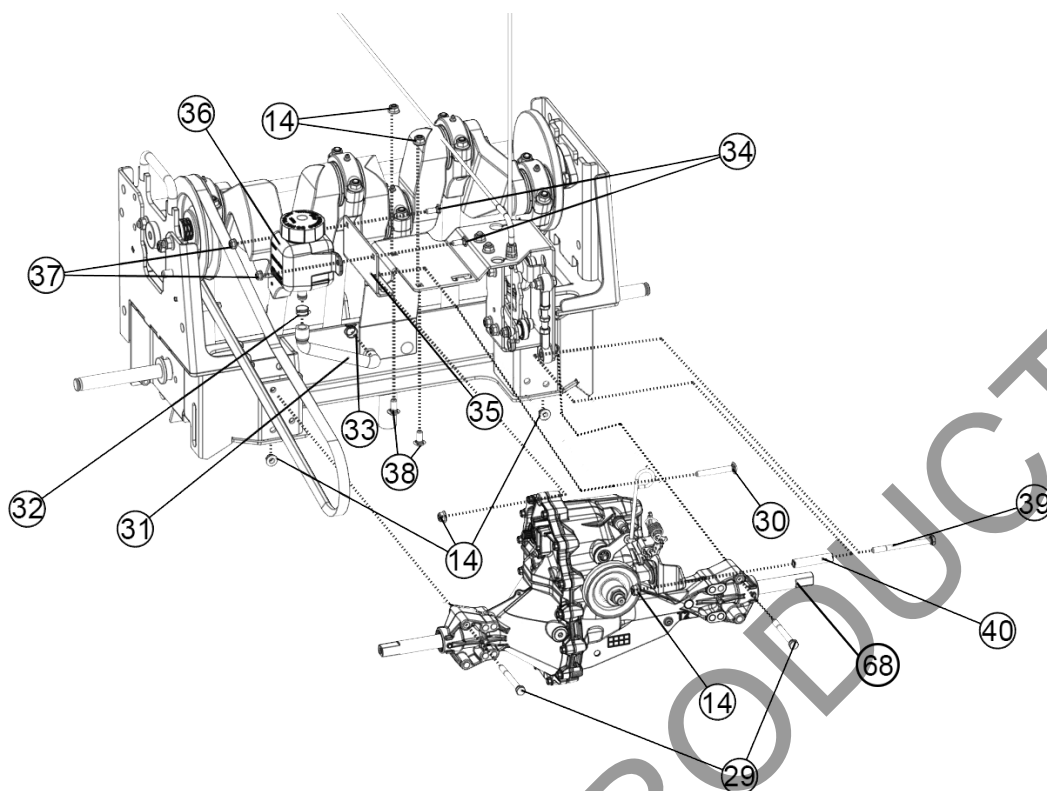

PL2501SPH & PL2501SPV

| Item No. | Description | Part No. | QTY |
|----------|---|----------|-----|
| 14 | NUT-HEX-NYLK, FLG .3125"-18 ZP | 8165002 | 2 |
| 29 | SCREWCAP 5/16"-18 X 3" GR 5 HCS ZP | 8041036 | 2 |
| 30 | BLT-RDHDSSQNK, .3125"-18 X 2.250 G5 YZ | 8024057 | 1 |
| 31 | HOSE, EXPANSION TANK | 382293 | 1 |
| 32 | CLAMP, HOSE CTL Ø.645" ID X .030" THICK | 382283 | 1 |
| 33 | CLAMP, HOSE CTL Ø.583" ID X .030" THICK | 382281 | 1 |
| 34 | BOLT CARRIAGE 1/4-20 X 3/4" ZP | 8024021 | 2 |
| 35 | PLATE, EXPANSION TANK MNT | 382299 | 1 |
| 36 | TANK, EXPANSION | 5100473 | 1 |
| 37 | NUT-HEX-NYLK, FLG .250"-20 ZP | 8165001 | 2 |
| 38 | BOLT CARRIAGE 5/16-18 X 3/4" ZP SHRT NK | 362224 | 2 |
| 39 | SCREWCAP 5/16"-18 X 3 1/2" GR 5 HCS ZP | 8041038 | 1 |
| 40 | SPACER, .500" OD X 2.313" ZP | 382229 | 1 |
| 68 | ASM, TRANSAXLE REPLACEMENT | 382603 | 2 |

Note: Item 68 (P/N 382603 - ASM, TRANSAXLE REPLACEMENT) includes:

- Item 31 (P/N 382293)
- Item 32 (P/N 382283)
- Item 33 (P/N 382281)
- Item 36 (P/N 5100473)

PL2501SP Parts Drawings

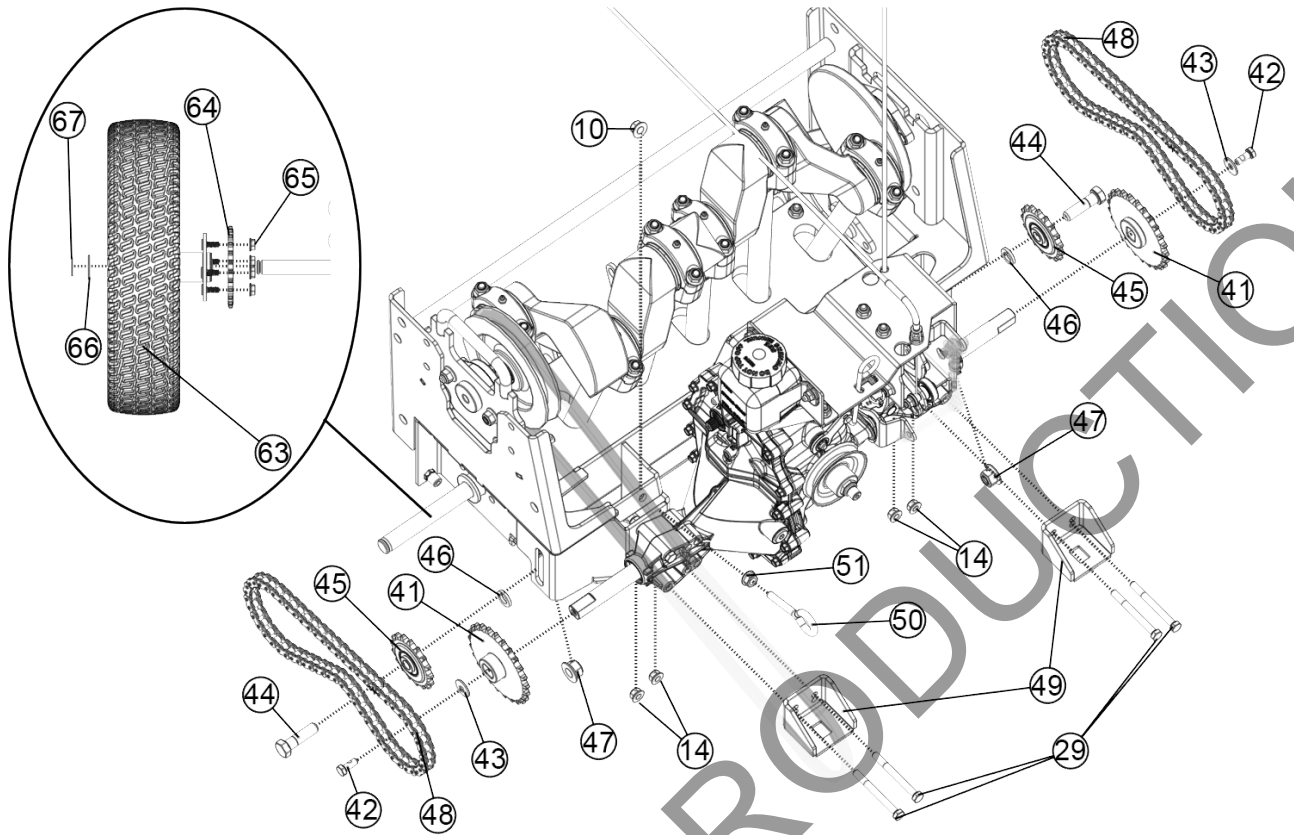

PL2501SPH & PL2501SPV

| Item No. | Description | Part No. | QTY |
|----------|--|----------|-----|
| 10 | NUT-HEX-NYLK, FLG .375"-16 ZP | 8165003 | 1 |
| 14 | NUT-HEX-NYLK, FLG .3125"-18 ZP | 8165002 | 4 |
| 29 | SCREWCAP 5/16"-18 X 3" GR 5 HCS ZP | 8041036 | 4 |
| 41 | WA, SPROCKET WHEEL DRIVE | 382105 | 2 |
| 42 | SCR-CAP, HEX .3125"-24 X .750" EP42 G5ZP | 8042026 | 2 |
| 43 | WSHR-STL, BLV .322" X .938" X .072" MZ | 8181014 | 2 |
| 44 | SCREWCAP 1/2"-13 X 1 3/4" HCS ZP GR. 5 | 8041097 | 2 |
| 45 | SPROCKET, IDLER 17T X 1/2" BORE | 373229 | 2 |
| 46 | WSHR-STL,FLT .500"X.875"X.134" MAB ZP | 382277 | 2 |
| 47 | NUT-HEX-NYLK, FLG .500"-13 ZP | 8165005 | 2 |
| 48 | CHAIN, #40 X 61 PITCHES | 371297 | 2 |
| 49 | WA, FRONT TRANS MNT | 382120 | 2 |
| 50 | BLT-HOOK, .375"-16 X 3.75" OAL W/NUT | 382340 | 1 |
| 51 | NUT 3/8-16 SER. HEX WSHR FLNG | 791079 | 1 |
| 63 | ASM, WHEEL & TIRE PLUGR TURF | 382239 | 2 |
| 64 | SPROCKET, RWD 25T 40 | 382253 | 2 |
| 65 | NUT 5/16"-18 SER. HEX WSHR FLNG ZP | 350346 | 8 |
| 66 | WASHER .765" IDX1.25"ODX.06" | 850238 | 2 |
| 67 | RING RETAINING "E" 3/4" | 850230 | 2 |

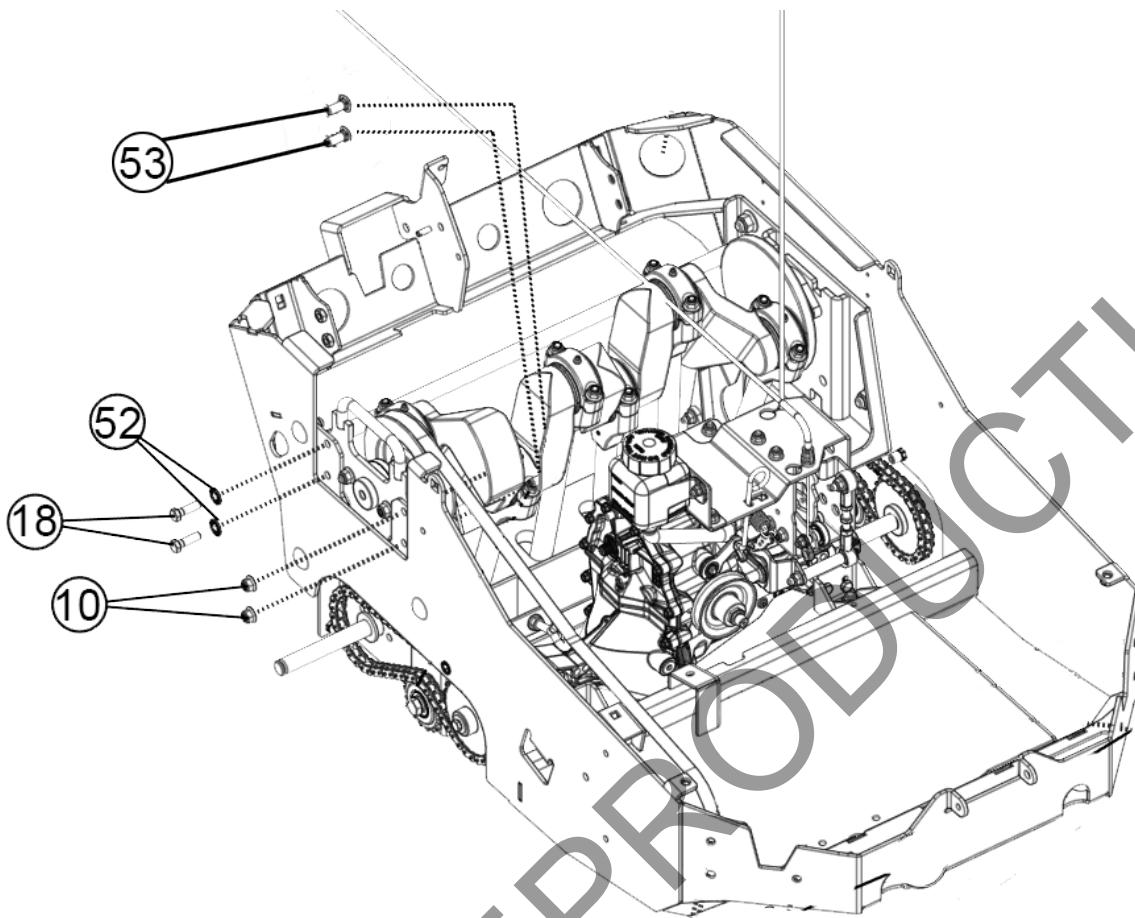

PL2501SPH & PL2501SPV

| Item No. | Description | Part No. | QTY |
|----------|--|----------|-----|
| 10 | NUT-HEX-NYLK, FLG .375"-16 ZP | 8165003 | 2 |
| 18 | SCREWCAP 3/8"-16 X 1 1/4" HCS ZP | 8041051 | 2 |
| 52 | WSHR-STL, BLV, 402 X .877 X .063 CN MZ | 8181011 | 2 |
| 53 | BLT-RDHDSSQNK, .375"-16 X 1.000 G5 ZP | 8024058 | 8 |

NOT FOR REPRODUCTION

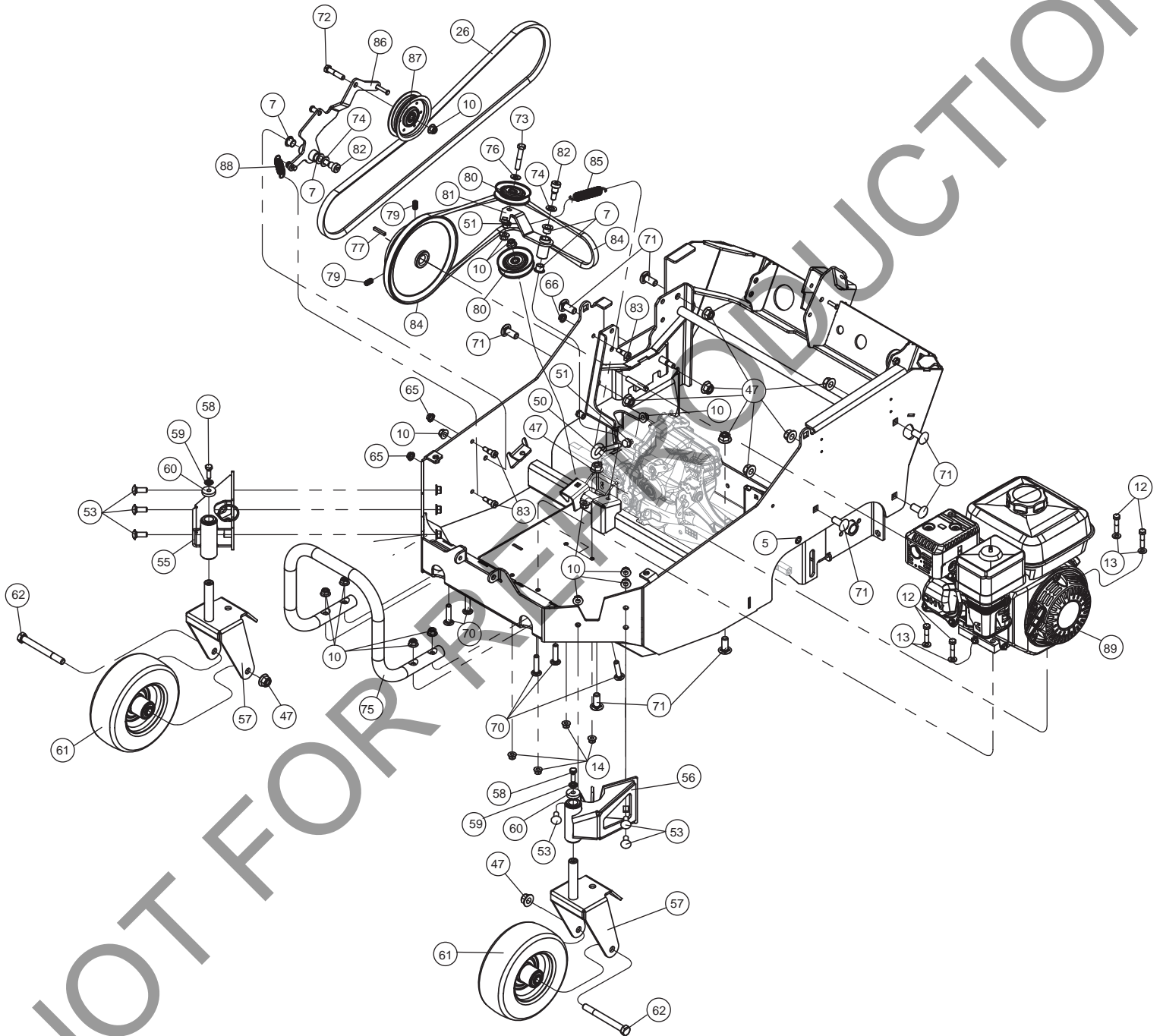

PL2501SP Parts Drawings

| | | PL2501SPH | PL2501SPV | | |
|----------|--|-----------|-----------|----------|-----|
| Item No. | Description | Part No. | QTY | Part No. | QTY |
| 5 | NUT INSERT HEX 5/16-18 | REF | 4 | REF | 4 |
| 7 | BUSHING, .500" I.D. | 362254 | 8 | 362254 | 8 |
| 10 | NUT-HEX-NYLK, FLG .375"-16 ZP | 8165003 | 16 | 8165003 | 16 |
| 12 | SCREWCAP 5/16"-18 X 1 1/2" GR 5 HCS ZP | 8041030 | 4 | 8041030 | 4 |
| 13 | WASHER 5/16 SAE Z/P | 8172008 | 4 | 8172008 | 4 |
| 14 | NUT-HEX-NYLK, FLG .3125"-18 ZP | 8165002 | 4 | 8165002 | 4 |
| 26 | BELT, V, 5L 61.82EL OHR ETH, AMD CD | 382273 | 1 | 382273 | 1 |
| 47 | NUT-HEX-NYLK, FLG .500"-13 ZP | 8165005 | 10 | 8165005 | 10 |
| 50 | BLT-HOOK, .375"-16 X 3.75" OAL W/NUT | 382340 | 1 | 382340 | 1 |
| 51 | NUT-HEX-FGLK, .375"-16 G5 ZP | 791079 | 2 | 791079 | 2 |
| 53 | BLT-RDHDSSQNK, .375"-16 X 1.000 G5 ZP | 8024058 | 6 | 8024058 | 6 |
| 55 | ASM, SUB CASTER WHEEL RH | 382011-S | 1 | 382011-S | 1 |
| 56 | ASM, SUB CASTER WHEEL LH | 382012-S | 1 | 382012-S | 1 |
| 57 | WA, CASTER WHEEL | 382125 | 2 | 382125 | 2 |
| 58 | SCREWCAP 5/16"-18 X 1" GR 5 HCS ZP | 8041028 | 2 | 8041028 | 2 |
| 59 | WASHER, BELLEVILLE CONTACT .323X.717X.05 | 8181010 | 2 | 8181010 | 2 |
| 60 | WASHER 1.125 OD x 0.344 ID x .25 THK ZP | 441150 | 2 | 441150 | 2 |
| 61 | WHEEL, 8" X 3" HEAVY DUTY | 373300 | 2 | 373300 | 2 |
| 62 | SCREWCAP 1/2"-13 X 4 3/4 HCS ZP GR. 5 | 8041108 | 2 | 8041108 | 2 |
| 65 | NUT 5/16"-18 SER. HEX WSHR FLNG ZP | 350346 | 3 | 350346 | 3 |
| 70 | BLT-RDHDSSQNK, .375"-16 X 1.750" G5 ZP | 8024067 | 5 | 8024067 | 5 |
| 71 | BLT-RDHDSSQNK, .500"-13 X 1.250" G5 ZP | 8024097 | 8 | 8024097 | 8 |
| 72 | SCREWCAP 3/8"-16 X 1 3/4" HCS ZP | 8041053 | 1 | 8041053 | 1 |
| 73 | SCREWCAP 3/8"-16 X 2" HCS ZP | 8041054 | 1 | 8041054 | 1 |
| 74 | WSHR-STL,FLT .500"X.875"X.0747" MAB ZP | 382252 | 2 | 382252 | 2 |
| 75 | GUARD, FRONT | 382401 | 1 | 382401 | 1 |
| 76 | WASHER 3/8 SAE 13/32 X 13/16 X 1/16 | 8172009 | 1 | 8172009 | 1 |
| 77 | KEY 3/16" SQ X 1 1/4" | 9201080 | 1 | 9201080 | 1 |
| 79 | SCREW SET 3/8-16 X 3/4 CUP POINT | 380218 | 2 | 380218 | 2 |
| 80 | PULLEY 3V GROOVE IDLER | 351216 | 2 | 351216 | 2 |
| 81 | WA, MULE DRIVE | 382109 | 1 | 382109 | 1 |
| 82 | BLT-SLDR,SH.500"X2.00",.375"-16X.63"G8ZP | 382295 | 2 | 382295 | 2 |
| 83 | BLT-SLDR,SH.375"X3.25",.313"-18X.50"G8ZP | 351316 | 3 | 351316 | 3 |
| 84 | BELT, V, 3V 53.00EL OHR CL, PLY CD | 382268 | 1 | 382268 | 1 |
| 85 | SPRING, EXT 4.090" X Ø.701 X 14LBF/IN | 382338 | 1 | 382338 | 1 |
| 86 | WA, IDLER ARM | 382107 | 1 | 382107 | 1 |
| 87 | PULLEY IDLER 4.00" OD X 3/8" BORE | 500113 | 1 | 500113 | 1 |
| 88 | SPRING IDLER UPPER OS900SP | 351275 | 1 | 351275 | 1 |
| 89 | ENGINE 5.5 HP HONDA GX160UT2HX2 W/GRBOX | 360126 | 1 | - | - |
| | ENGINE, VANGUARD 203CC W/6:1 3 AT 3 | - | - | 382323 | 1 |

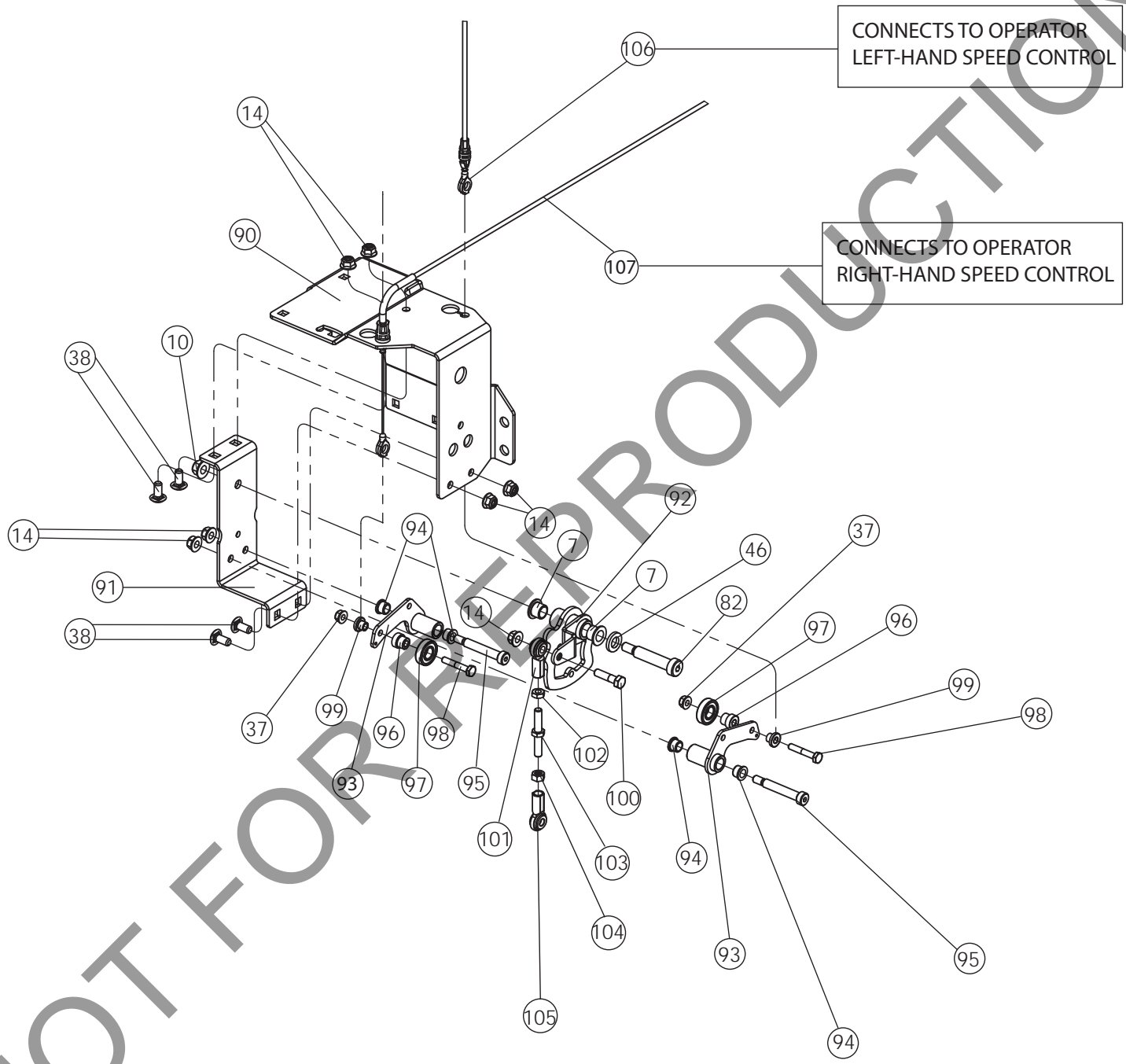

PL2501SP Parts Drawings

PL2501SPH & PL2501SPV

| Item No. | Description | Part No. | QTY |
|----------|--|----------|-----|
| 7 | BUSHING, .500" I.D. | 362254 | 2 |
| 10 | NUT-HEX-NYLK, FLG .375"-16 ZP | 8165003 | 1 |
| 14 | NUT-HEX-NYLK, FLG .3125"-18 ZP | 8165002 | 7 |
| 37 | NUT-HEX-NYLK, FLG .250"-20 ZP | 8165001 | 2 |
| 38 | BOLT CARRIAGE 5/16-18 X 3/4" ZP SHRT NK | 362224 | 4 |
| 46 | WSHR-STL,FLT .500"X.875"X.134" MAB ZP | 382277 | 1 |
| 82 | BLT-SLDR,SH.500"X2.00",.375"-16X.63"G8ZP | 382295 | 1 |
| 90 | ASM, PAINTED CABLE GUIDE W/DECAL | 382122-S | 1 |
| 91 | PLATE, LONGMEYER BOX MNT | 382208 | 1 |
| 92 | WA, EQUAL SPEED CAM | 382140 | 1 |
| 93 | BELLCRANK BC2600 WA | 501114 | 2 |
| 94 | BUSHING 3/8 ID x 1/2 OD x 3/8 | 840078 | 4 |
| 95 | BLT-SLDR,SH.375"X1.75",.313"-18X.50"G8ZP | 351258 | 2 |
| 96 | SPACER, SPEED CONTROL STEPPED PM | 351347 | 2 |
| 97 | BEARING .500 ID x 1.125 OD X .313 THK | 351257 | 2 |
| 98 | SCREWCAP 1/4"-20 X 1 1/2" HCS ZP | 8041008 | 2 |
| 99 | SPACER, SPEED CONTROL EYELET PM | 351348 | 2 |
| 100 | SCREWCAP 5/16"-18 X 1 1/4" GR 5 HCS ZP | 8041029 | 1 |
| 101 | SPHERICAL ROD END MSF-5 | 351278 | 1 |
| 102 | NUT-HEX, JAM, .3125"-24 G2 YZ | 8150002 | 1 |
| 103 | JACKSCREW, 5/16"-24 RT AND LFT | 362266 | 1 |
| 104 | NUT 5/16-24 LFT HAND FIN HEX ZP | 362322 | 1 |
| 105 | SPHERICAL ROD END, FEMALE 5/16"-24 LFT | 362269 | 1 |
| 106 | CABLE, SPEED CONTROL RT | 351219 | 1 |
| 107 | CABLE, SPEED CONTROL ASSY PL | 382274 | 1 |

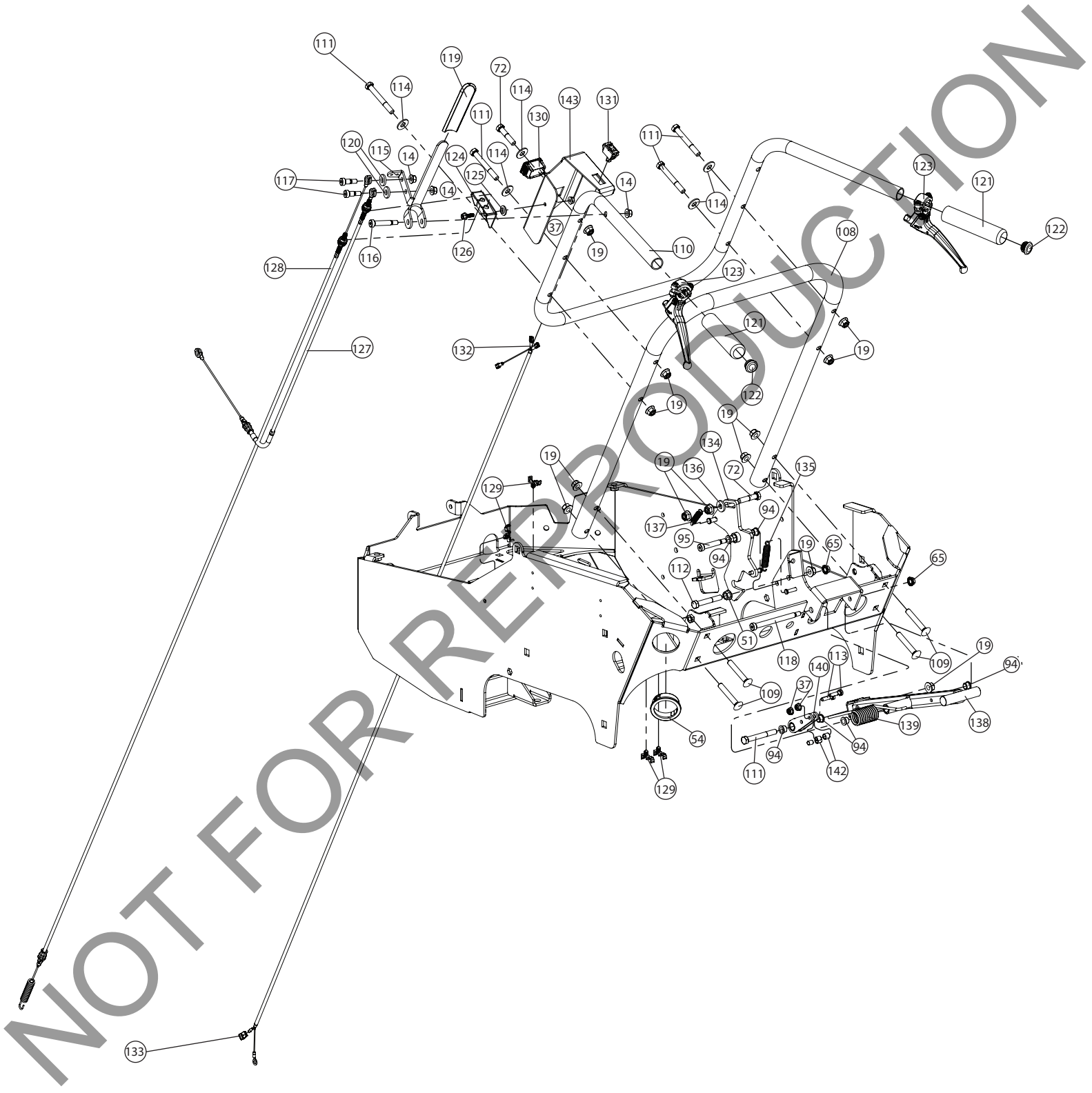

PL2501SP Parts Drawings

PL2501SPH & PL2501SPV

| Item No. | Description | Part No. | QTY |
|----------|--|----------|-----|
| 14 | NUT-HEX-NYLK, FLG .3125"-18 ZP | 8165002 | 3 |
| 19 | NUT-HEX-NYLK, FLG .375"-16 ZP | 8165003 | 13 |
| 37 | NUT-HEX-NYLK, FLG .250"-20 ZP | 8165001 | 3 |
| 51 | NUT-HEX-FGLK, .375"-16 G5 ZP | 791079 | 1 |
| 54 | BUSHING, SNAP 1.81" ID | 382292 | 1 |
| 65 | NUT 5/16"-18 SER. HEX WSHR FLNG ZP | 350346 | 2 |
| 72 | SCREWCAP 3/8"-16 X 1 3/4" HCS ZP | 8041053 | 2 |
| 94 | BUSHING 3/8 ID x 1/2 OD x 3/8 | 840078 | 6 |
| 95 | BLT-SLDR,SH.375"X1.75",.313"-18X.50"G8ZP | 351258 | 1 |
| 108 | HANDLEBAR, LOWER PL2501 | 382404 | 1 |
| 109 | BOLT CARRIAGE 3/8-16 X 2 1/2" ZP | 8024064 | 4 |
| 110 | HANDLEBAR, UPPER PL2501 | 382403 | 1 |
| 111 | SCREWCAP 3/8"-16 X 3" HCS ZP | 8041058 | 5 |
| 112 | SCREWCAP 3/8"-16 X 2 1/2" HCS ZP | 8041056 | 1 |
| 113 | SCREWCAP 1/4"-20 X 1" HCS ZP | 8041006 | 2 |
| 114 | SCR-CAP, HEX .250"-20 X 0.750" G8 YZ | 8071004 | 5 |
| 115 | LEVER CLUTCH/SEED DROP OS900SP | 351212 | 1 |
| 116 | BLT-SLDR,SH.375"X1.50",.313"-18X.50"G8ZP | 501313 | 1 |
| 117 | BLT-SLDR,SH.375"X.50",.313"-18X.50"G8ZP | 382263 | 2 |
| 118 | BLT-SLDR,SH.375"X4.00",.313"-18X.50"G8ZP | 382285 | 1 |
| 119 | GRIP LEVER .125" X 1" X 5" ORANGE | 500379 | 1 |
| 120 | WSHR-STL, FLT, .406" X .875" X .125" ZP | 382202 | 2 |
| 121 | GRIP HANDLE 1" X 5.5" | 500267 | 2 |
| 122 | INSERT GLIDE 1 INCH 10-14 GA | 890132 | 2 |
| 123 | MAGURA CONTROL | 351209 | 2 |
| 124 | BRKT, CABLE MOUNT | 382275 | 1 |
| 125 | WASHER, SHOULDER .265"X.437"X.125" NYL | 382232 | 1 |
| 126 | SCR-MAC, HWH .250"-20 X .750" G2 ZP | 8059134 | 1 |
| 127 | CABLE, AUTO ENGAGE | 382303 | 1 |
| 128 | CABLE, CLUTCH | 382304 | 1 |
| 129 | CLIP CABLE - THICK PANEL | 371222 | 4 |
| 130 | HOURLMETER, INDUCTIVE PANEL MOUNT | 373305 | 1 |
| 131 | SWITCH LKG RKR B&S #493521 | 500281 | 1 |
| 132 | HARNESS, STOP SWITCH WIRE | 373312 | 1 |
| 133 | TERMINAL 18-14 BLUE T-TAP | 840215 | 1 |
| 134 | WA, TINE LATCH | 382119 | 1 |
| 135 | SPRING EXTENSION 1/2 OD, 3-5" | 381663 | 1 |
| 136 | WSHR-NYL, FLT, .385" X .880" X .125" | 382241 | 1 |
| 137 | SPRING EXTENSION | 800242 | 1 |
| 138 | WA, LIFT PEDAL | 382117 | 1 |
| 139 | SPRING,TOR,Ø.865IDX.180"WDX0.702#-IN/° | 382294 | 1 |
| 140 | WA, UPPER TINE LINK | 382127 | 1 |
| 142 | BRG, SLEEVE .250" X .4375" X .375" BNZ | 382339 | 2 |
| 143 | WA, SWITCH & HOUR METER MOUNT | 382121 | 1 |

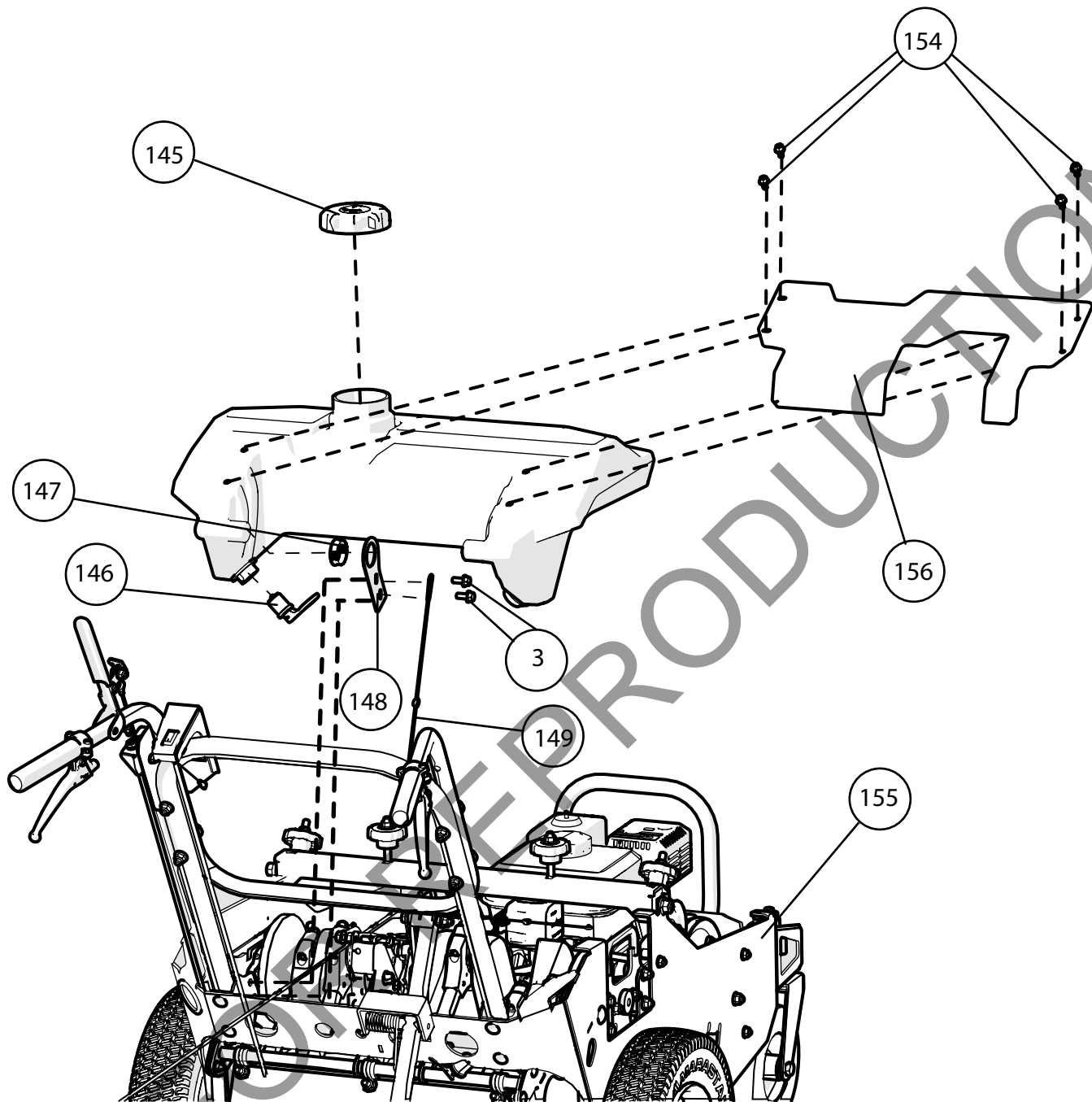

PL2501SPH & PL2501SPV

| Item No. | Description | Part No. | QTY |
|----------|--|----------|-----|
| 3 | SER. HEX WSHR FLNG SCR 5/16" - 18 x 3/4" | 351264 | 1 |
| 144 | TANK, WATER PL2501 | 382301 | 1 |
| 145 | CAP KELCH 3.5" W/LANYARD | 360256 | 2 |
| 146 | PLUG DRAIN 1" | 360293 | 2 |
| 147 | BUSHING, SNAP 1.31" ID | 382240 | 2 |
| 148 | BRKT, PIVOT WATER TANK | 382289 | 2 |
| 149 | LANYARD PLASTIC 10" | 360243 | 4 |
| 154 | BOLT 1/4-20 x 1/2 SER FLANGE | 812381 | 4 |
| 155 | ASM, PAINTED BODY W/DECALS & INSERTS | 382113-S | 1 |
| 156 | ASM, PAINTED COVER W/DECALS | 382256-S | 1 |

PL2501SP Parts Drawings

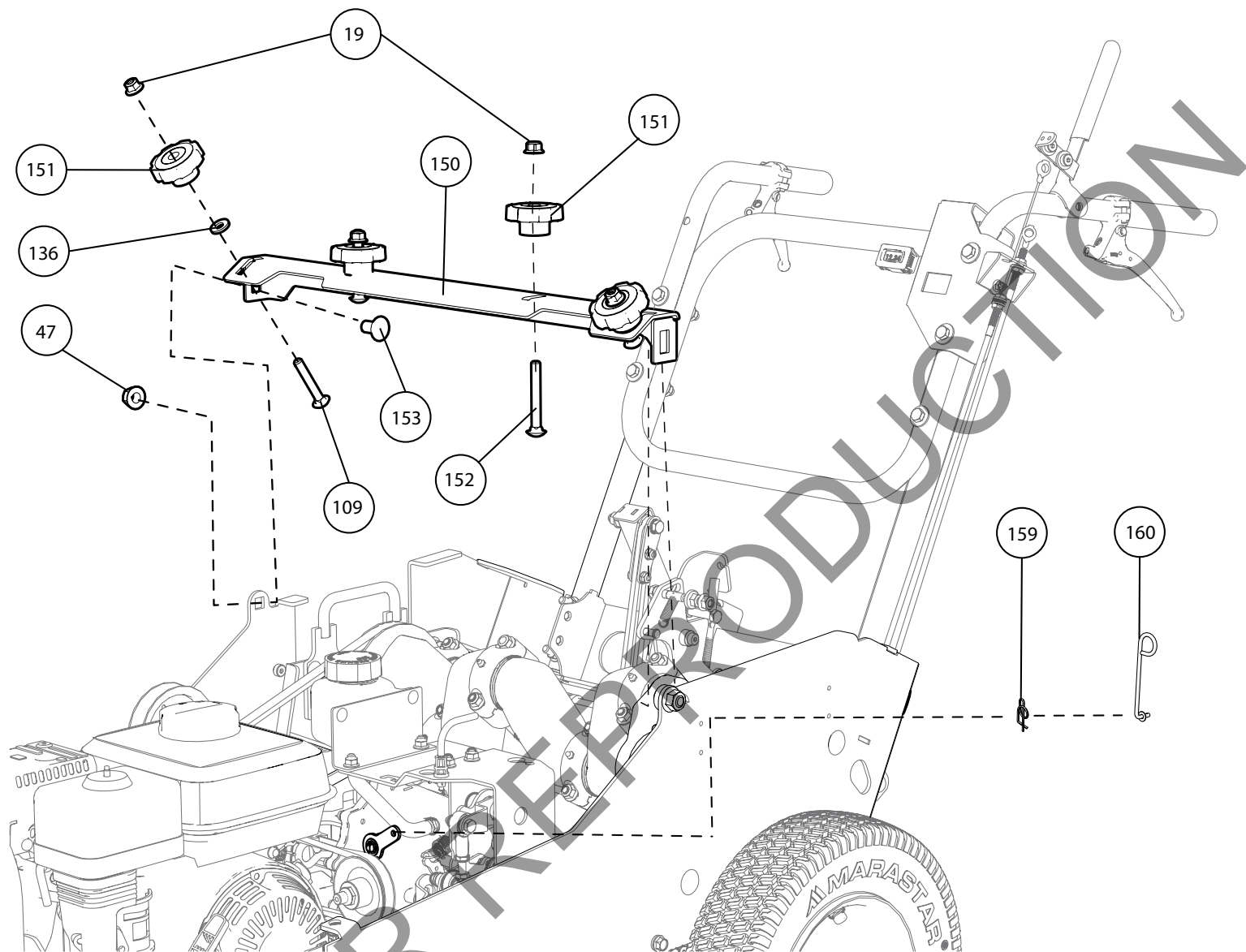

PL2501SPH & PL2501SPV

| Item No. | Description | Part No. | QTY |
|----------|---------------------------------------|----------|-----|
| 19 | NUT-HEX-NYLK, FLG .375"-16 ZP | 8165003 | 4 |
| 47 | NUT-HEX-NYLK, FLG .500"-13 ZP | 8165005 | 2 |
| 109 | BOLT CARRIAGE 3/8-16 X 2 1/2" ZP | 8024064 | 2 |
| 136 | WSHR-NYL, FLT, .385" X .880" X .125" | 382241 | 2 |
| 150 | SUPPORT, SHIELD & TANK | 382223 | 1 |
| 151 | KNOB 3/8-18, SOLID HUB | 811230 | 4 |
| 152 | BOLT CARRIAGE 3/8-16 X 3" ZP | 8024066 | 2 |
| 153 | BLT-RDHDSQNK, .500"-13 X 1.000" G5 ZP | 8024098 | 2 |
| 159 | PIN, RUE RING 0.250" | 371275 | 1 |
| 160 | ROD, TRANSMISSION BYPASS | 382324 | 1 |